

**Motori corrente continua
Direct current motors
Gleichstrommotoren**

serie QCC

Size 71 ÷ 160

DATI GENERALI	GENERAL DATA	ALLGEMEINE DATEN
Forma costruttiva	Mounting	Bauformen IM 2001 (B35) – IM 3001 (B5) ²⁾
Protezione motore	Motor Protection	Schutzart OCCA, QCCAS IP 23S – QCCH, QCCHAS IP 54 (IP 55) ²⁾
Equilibratura	Balancing	Auswuchten grado R – R degree – grad R
Isolamento	Insulation	Isolation classe F – F class – F Klasse
Protezione termica	Thermal Protection	Thermikschutz PTO (Klixon) ²⁾ – PTC ²⁾
Rumore L _w	Noise L _w	Geräuschpegel L _w L _w < 85 dB (A)
Raffreddamento	Cooling System	Kühlung OCCA IC01 – QCCAS IC06 – QCCH IC00 – QCCHAS IC0641
Installazione	Ambient	Umgebungstemperatur - 15 / + 40°C - 1000 m a.s.l.

ELETTROVENTILATORE	ELECTRIC FAN	ELEKTROLÜFTER	RADIAL FAN (QCCAS, QCCHAS)				
Grandezza motore	Motor size	MotorBaugröße	71	80	100	132	160
Alimentazione	Power supply	Versorgung	1-phase		3-phase 400/460Vac 50/60Hz		
Corrente	Current	Strom	A	0.15/0.17	0.27/0.30	0.30/0.36	0.7 2.9
Potenza	Power	Leistung	W	33/45	70/85	90/110	250 1100
Portata aria	Air flow	Fordermenge	m ³ /min	1.8	3.5	6	9 15
Pressione	Pressure	Druck	Pa	240	380	470	580 800
Tipo	Type	Typ	40	50B/2	56A/2	63B/2	80B/2

1-phase: 220/230V 50/60Hz

SPAZZOLE	CARBON BRUSHES	KOHLEBURSTEN						
Grandezza motore	Motor size	MotorBaugröße	71S-M	71L-P	80	100	132	160
Tipo	Type	Typ	E 49 X					
Dimensioni	Dimensions	Abmessungen	6x12x25	8x16x25	10x20x40	12.5x20.40	10x25x40	12.5x32x40
Quantità	Quantity	Anzahl	2	2	2	2 / 4	4 / 8	4 / 8

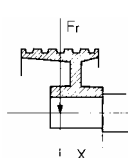
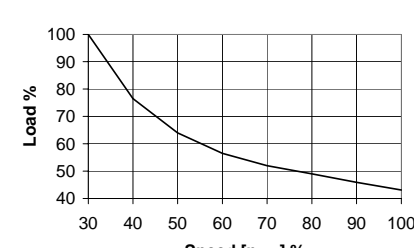
CUSCINETTI		BEARINGS		WÄZLAGER		RADIAL LOAD DIAGRAM	
Motor Size	D.E. side Brg. code	D.E. side ²⁾ Brg. code	N.D.E. side Brg. code	Max. rad. load N @ 1500rpm	Distance X mm		
71 S-M	6202 2RS	-	6201 2RS	300	15		
71 L-P	6204 2RS	-	6201 2RS	450	20		
80	6205 2RS	-	6304 2RS	800	25		
80	6206 2RS	-	6304 2RS	1200	30		
100	6208 2RS	NU 208 ³⁾	6306 2RS	1600 (2500) ³⁾	40		
132	6309 2RS	NU 309 ³⁾	6209 2RS	2300 (4000) ³⁾	55		
160	6310 2RS	NU 310 ³⁾	6309 2RS	3000 (5000) ³⁾	55		

D.E. (Lato comando, drive end, Abtriebsseite) - N.D.E. (Lato opposto comando, non-drive end, Rückseite)
(Cuscinetto a rulli, Roller bearing, Rollenlager) ³⁾

FRENO DI STAZIONAMENTO ²⁾	HOLDING BRAKE ²⁾	BREMSE ²⁾	BRAKE TYPE - MOTOR SIZE				
Grandezza motore	Motor size	Motor-Baugröße	71	80	100	132	160
Tipo di freno	Brake type	Bremstyp	Rr 10	Rr 30	Rr 50	Rr 150	Rr 180
Coppia statica massima	Max. static torque	Max. statisches Mom.	Nm	10	30	50	130 160
Inerzia del freno	Brake inertia	Bremse trägheitsm	J	0.00011	0.0003	0.0006	0.0023 0.0028
Alimentazione	Power supply	Versorgung	Vdc	96	96	96	96 96
Potenza	Power	Leistung	W	16	22	25	33 50

2) Opzione disponibile a richiesta – Option available on request – Verfügbares Sonderzubehör

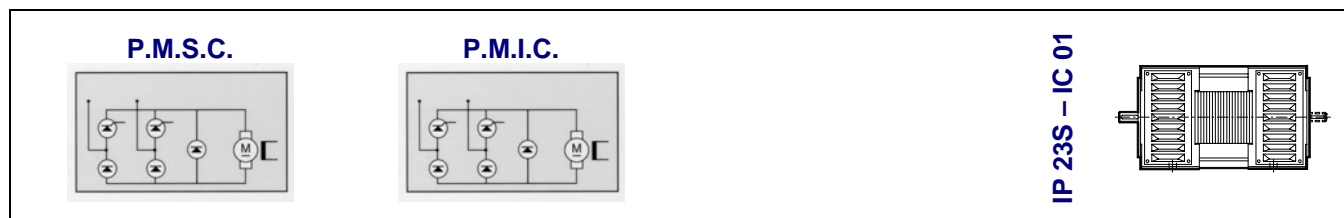

71S QCCA	Peso Weight	8,7 Kg				Inerzia Inertia	J 0,0010 kgm ²				Eccitazione Field	110-200-330 Vdc		P 44 W	K 65 ms	
	170 V				150 V				M (S1)	I Max. 15"-5'	Arm. max.	N max.	Ind. L	Res. 115°C	Cod. Arm.	Spaz. Brush nr.
	P kW	N rpm	I A	η %	P kW	N rpm	I A	η %	Nm	A	V	rpm	mH	Ω	--	nr.
	0,55	3000	4,1	78,9	0,47	2600	4,0	78,3	1,8	7	200	3500	39	6,8	I8	2
	0,41	2500	3,2	76,6	0,36	2200	3,1	76,4	1,6	5	200	3000	54	9,1	1A6	2

71M QCCA	Peso Weight	11,2 Kg				Inerzia Inertia	J 0,0015 kgm ²				Eccitazione Field	110-200-330 Vdc		P 52 W	K 70 ms	
	170 V				150 V				M (S1)	I Max. 15"-5'	Arm. max.	N max.	Ind. L	Res. 115°C	Cod. Arm.	Spaz. Brush nr.
	P kW	N rpm	I A	η %	P kW	N rpm	I A	η %	Nm	A	V	rpm	mH	Ω	--	nr.
	0,73	3000	5,5	78,1	0,64	2600	5,4	78,4	2,3	9	200	3500	23	4,0	F8	2
	0,57	2500	4,3	77,3	0,5	2200	4,3	77,0	2,2	7	200	3000	35	5,8	H0	2

71L QCCA	Peso Weight	13,6 Kg				Inerzia Inertia	J 0,0020 kgm ²				Eccitazione Field	110-200-330 Vdc		P 72 W	K 80 ms	
	170 V				150 V				M (S1)	I Max. 15"-5'	Arm. max.	N max.	Ind. L	Res. 115°C	Cod. Arm.	Spaz. Brush nr.
	P kW	N rpm	I A	η %	P kW	N rpm	I A	η %	Nm	A	V	rpm	mH	Ω	--	nr.
	0,97	3000	7,0	81,5	0,84	2600	7,0	80,2	3,1	11	200	3500	15	2,5	E0	2
	0,76	2500	5,6	80,3	0,66	2200	5,6	79,1	2,9	9	200	3000	22	3,4	F0	2

71P QCCA	Peso Weight	18,1 Kg				Inerzia Inertia	J 0,0030 kgm ²				Eccitazione Field	110-200-330 Vdc		P 96 W	K 90 ms	
	170 V				150 V				M (S1)	I Max. 15"-5'	Arm. max.	N max.	Ind. L	Res. 115°C	Cod. Arm.	Spaz. Brush nr.
	P kW	N rpm	I A	η %	P kW	N rpm	I A	η %	Nm	A	V	rpm	mH	Ω	--	nr.
	1,46	3000	10,7	80,6	1,27	2600	10,5	80,7	4,6	17	200	3500	10	1,5	C4	2
	1,18	2500	8,7	80,2	1,03	2200	8,7	79,4	4,5	14	200	3000	14	1,9	D0	2

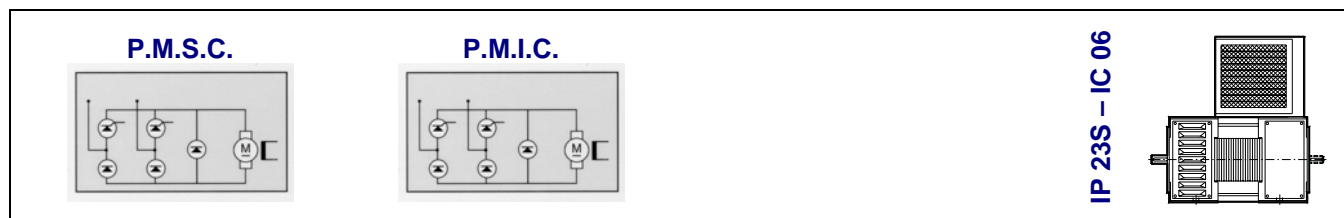

71S QCCAS	Peso Weight	10,6 Kg				Inerzia Inertia	J 0,0010 kgm ²				Eccitazione Field	110-200-330 Vdc		P 44 W	K 65 ms	
	170 V				150 V				M (S1)	I Max. 15"-5'	Arm. max.	N max.	Ind. L	Res. 115°C	Cod. Arm.	Spaz. Brush nr.
	P kW	N rpm	I A	η %	P kW	N rpm	I A	η %	Nm	A	V	rpm	mH	Ω	--	nr.
	0,65	3000	4,9	78,0	0,57	2600	4,8	78,7	2,1	7	200	3500	39	6,8	I8	2
	0,55	2500	4,1	78,7	0,48	2200	4,1	77,9	2,1	6	200	3000	54	9,1	1A6	2
	0,45	2000	3,4	77,2	0,38	1700	3,3	76,8	2,1	5	210	2500	94	16	1D6	2
0,33	1500	2,6	74,7	0,29	1300	2,6	75,5	2,1	4	220	2000	170	25	114	2	

71M QCCAS	Peso Weight	13,1 Kg				Inerzia Inertia	J 0,0015 kgm ²				Eccitazione Field	110-200-330 Vdc		P 52 W	K 70 ms	
	170 V				150 V				M (S1)	I Max. 15"-5'	Arm. max.	N max.	Ind. L	Res. 115°C	Cod. Arm.	Spaz. Brush nr.
	P kW	N rpm	I A	η %	P kW	N rpm	I A	η %	Nm	A	V	rpm	mH	Ω	--	nr.
	0,94	3000	7,0	79,0	0,81	2600	6,9	78,3	3,0	11	200	3500	23	4,0	F8	2
	0,79	2500	6,0	77,5	0,70	2200	6,0	77,8	3,0	9	200	3000	35	5,8	H0	2
	0,63	2000	4,9	76,4	0,54	1700	4,7	76,6	3,0	7	210	2500	53	8,5	1Z0	2
0,48	1500	3,7	75,5	0,42	1300	3,7	76,1	3,1	6	220	2000	84	15	1C8	2	

71L QCCAS	Peso Weight	15,5 Kg				Inerzia Inertia	J 0,0020 kgm ²				Eccitazione Field	110-200-330 Vdc		P 72 W	K 80 ms	
	170 V				150 V				M (S1)	I Max. 15"-5'	Arm. max.	N max.	Ind. L	Res. 115°C	Cod. Arm.	Spaz. Brush nr.
	P kW	N rpm	I A	η %	P kW	N rpm	I A	η %	Nm	A	V	rpm	mH	Ω	--	nr.
	1,10	3000	8,0	81,1	0,95	2600	7,9	80,6	3,5	12	200	3500	15	2,5	E0	2
	0,91	2500	6,7	79,9	0,80	2200	6,7	79,6	3,5	10	200	3000	22	3,4	F0	2
	0,74	2000	5,5	79,7	0,63	1700	5,3	79,2	3,5	8	210	2500	38	5,3	G6	2
0,55	1500	4,2	78,0	0,48	1300	4,0	80,0	3,5	6	220	2000	64	9,4	1Z0	2	

71P QCCAS	Peso Weight	20,0 Kg				Inerzia Inertia	J 0,0030 kgm ²				Eccitazione Field	110-200-330 Vdc		P 96 W	K 90 ms	
	170 V				150 V				M (S1)	I Max. 15"-5'	Arm. max.	N max.	Ind. L	Res. 115°C	Cod. Arm.	Spaz. Brush nr.
	P kW	N rpm	I A	η %	P kW	N rpm	I A	η %	Nm	A	V	rpm	mH	Ω	--	nr.
	1,61	3000	11,7	80,9	1,40	2600	11,5	81,2	5,1	18	200	3500	10	1,5	C4	2
	1,34	2500	9,9	79,8	1,18	2200	9,9	79,5	5,1	15	200	3000	14	1,9	D0	2
	1,07	2000	8,0	78,9	0,91	1700	7,7	78,5	5,1	12	210	2500	22	3,4	E0	2
0,80	1500	6,0	78,4	0,70	1300	6,0	78,4	5,1	9	220	2000	40	4,9	F6	2	

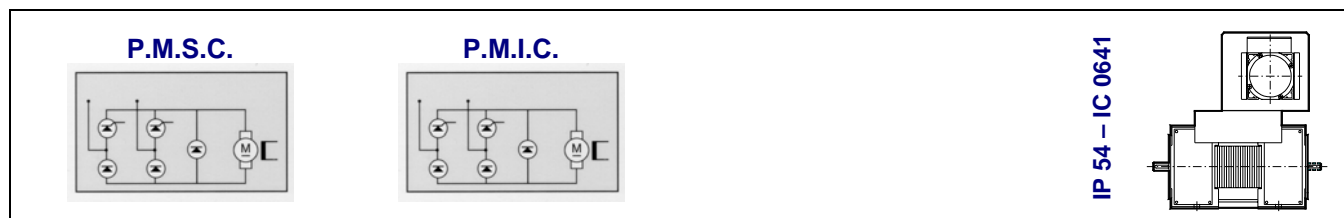

71S QCCHAS	Peso Weight	10,7 Kg				Inerzia Inertia	J 0,0010 kgm ²				Eccitazione Field	110-200-330 Vdc		P 44 W	K 65 ms	
	170 V				150 V				M (S1)	I Max. 15"-5'	Arm. max.	N max.	Ind. L	Res. 115°C	Cod. Arm.	Spaz. Brush nr.
	P kW	N rpm	I A	η %	P kW	N rpm	I A	η %	Nm	A	V	rpm	mH	Ω	--	nr.
	0,37	3000	2,8	77,7	0,32	2600	2,7	78,4	1,2	4	200	3500	39	6,8	I8	2
	0,31	2500	2,3	78,3	0,27	2200	2,3	76,9	1,2	3	200	3000	54	9,1	1A6	2
	0,25	2000	1,9	77,0	0,21	1700	1,9	75,7	1,2	3	210	2500	94	16	1D6	2
0,18	1500	1,5	73,0	0,16	1300	1,4	74,6	1,1	2	220	2000	170	25	1I4	2	

71M QCCHAS	Peso Weight	13,2 Kg				Inerzia Inertia	J 0,0015 kgm ²				Eccitazione Field	110-200-330 Vdc		P 52 W	K 70 ms	
	170 V				150 V				M (S1)	I Max. 15"-5'	Arm. max.	N max.	Ind. L	Res. 115°C	Cod. Arm.	Spaz. Brush nr.
	P kW	N rpm	I A	η %	P kW	N rpm	I A	η %	Nm	A	V	rpm	mH	Ω	--	nr.
	0,59	3000	4,4	78,9	0,51	2600	4,4	78,2	1,9	7	200	3500	23	4,0	F8	2
	0,49	2500	3,7	77,7	0,43	2200	3,7	76,6	1,9	6	200	3000	35	5,8	H0	2
	0,40	2000	3,0	78,4	0,34	1700	2,9	77,4	1,9	5	210	2500	53	8,5	1Z0	2
0,30	1500	2,3	76,7	0,26	1300	2,3	76,4	1,9	3	220	2000	84	15	1C8	2	

71L QCCHAS	Peso Weight	15,6 Kg				Inerzia Inertia	J 0,0020 kgm ²				Eccitazione Field	110-200-330 Vdc		P 72 W	K 80 ms	
	170 V				150 V				M (S1)	I Max. 15"-5'	Arm. max.	N max.	Ind. L	Res. 115°C	Cod. Arm.	Spaz. Brush nr.
	P kW	N rpm	I A	η %	P kW	N rpm	I A	η %	Nm	A	V	rpm	mH	Ω	--	nr.
	0,80	3000	5,9	80,3	0,7	2600	5,8	80,9	2,5	9	200	3500	15	2,5	E0	2
	0,67	2500	4,9	79,9	0,59	2200	4,9	79,6	2,6	7	200	3000	22	3,4	F0	2
	0,54	2000	4,0	80,2	0,45	1700	3,8	78,3	2,6	6	210	2500	38	5,3	G6	2
0,40	1500	3,0	78,4	0,35	1300	3,0	78,6	2,5	5	220	2000	64	9,4	1Z0	2	

71P QCCHAS	Peso Weight	20,1 Kg				Inerzia Inertia	J 0,0030 kgm ²				Eccitazione Field	110-200-330 Vdc		P 96 W	K 90 ms	
	170 V				150 V				M (S1)	I Max. 15"-5'	Arm. max.	N max.	Ind. L	Res. 115°C	Cod. Arm.	Spaz. Brush nr.
	P kW	N rpm	I A	η %	P kW	N rpm	I A	η %	Nm	A	V	rpm	mH	Ω	--	nr.
	1,20	3000	8,7	81,1	1,05	2600	8,6	81,6	3,8	13	200	3500	10	1,5	C4	2
	1,00	2500	7,3	80,6	0,87	2200	7,3	79,1	3,8	11	200	3000	14	1,9	D0	2
	0,80	2000	5,9	80,2	0,68	1700	5,7	80,0	3,8	9	210	2500	22	3,4	E0	2
0,60	1500	4,5	79,3	0,51	1300	4,4	77,6	3,8	7	220	2000	40	4,9	F6	2	

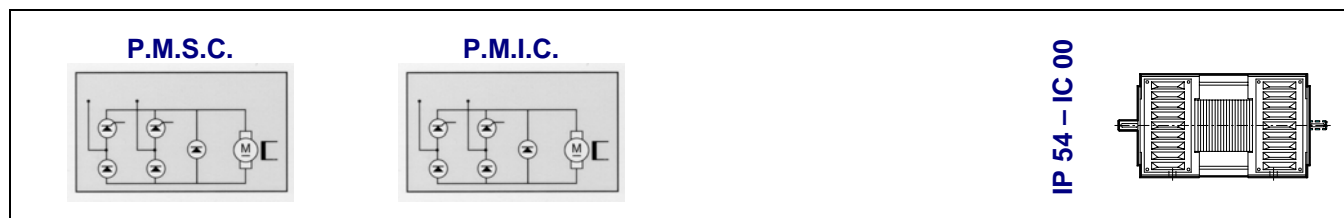

71M QCCH	Peso Weight	11,2 Kg				Inerzia Inertia	J 0,0015 kgm ²				Eccitazione Field	110-200-330 Vdc		P 52 W	K 70 ms	
	170 V				150 V				M (S1)	I Max. 15"-5'	Arm. max.	N max.	Ind. L	Res. 115°C	Cod. Arm.	Spaz. Brush nr.
	P kW	N rpm	I A	η %	P kW	N rpm	I A	η %	Nm	A	V	rpm	mH	Ω	--	nr.
	0,22	3000	1,6	79,9	0,19	2600	1,6	79,2	0,7	2	200	3500	23	4,0	F8	2
	0,18	2500	1,4	76,7	0,16	2200	1,4	77,3	0,7	2	200	3000	35	5,8	H0	2
	0,14	2000	1,1	73,5	0,12	1700	1,1	73,4	0,7	2	210	2500	53	9	1Z0	2
	0,11	1500	0,9	76,1	0,09	1300	0,8	71,4	0,7	1	220	2000	84	15	1C8	2

71L QCCH	Peso Weight	13,6 Kg				Inerzia Inertia	J 0,0020 kgm ²				Eccitazione Field	110-200-330 Vdc		P 72 W	K 80 ms	
	170 V				150 V				M (S1)	I Max. 15"-5'	Arm. max.	N max.	Ind. L	Res. 115°C	Cod. Arm.	Spaz. Brush nr.
	P kW	N rpm	I A	η %	P kW	N rpm	I A	η %	Nm	A	V	rpm	mH	Ω	--	nr.
	0,28	3000	2,1	79,6	0,24	2600	2,1	78,0	0,9	3	200	3500	15	2,5	E0	2
	0,23	2500	1,7	77,8	0,2	2200	1,7	76,6	0,9	3	200	3000	22	3,4	F0	2
	0,19	2000	1,4	79,3	0,16	1700	1,4	77,9	0,9	2	210	2500	38	5,3	G6	2
	0,14	1500	1,1	76,3	0,12	1300	1,1	75,5	0,9	2	220	2000	64	9	1Z0	2

71P QCCH	Peso Weight	18,1 Kg				Inerzia Inertia	J 0,0030 kgm ²				Eccitazione Field	110-200-330 Vdc		P 96 W	K 90 ms	
	170 V				150 V				M (S1)	I Max. 15"-5'	Arm. max.	N max.	Ind. L	Res. 115°C	Cod. Arm.	Spaz. Brush nr.
	P kW	N rpm	I A	η %	P kW	N rpm	I A	η %	Nm	A	V	rpm	mH	Ω	--	nr.
	0,43	3000	3,2	79,5	0,38	2600	3,1	80,7	1,4	5	200	3500	10	1,5	C4	2
	0,36	2500	2,7	79,3	0,32	2200	2,7	79,6	1,4	4	200	3000	14	1,9	D0	2
	0,29	2000	2,2	78,6	0,25	1700	2,1	79,4	1,4	3	210	2500	22	3,4	E0	2
	0,22	1500	1,7	78,4	0,19	1300	1,6	77,7	1,4	2	220	2000	40	4,9	F6	2

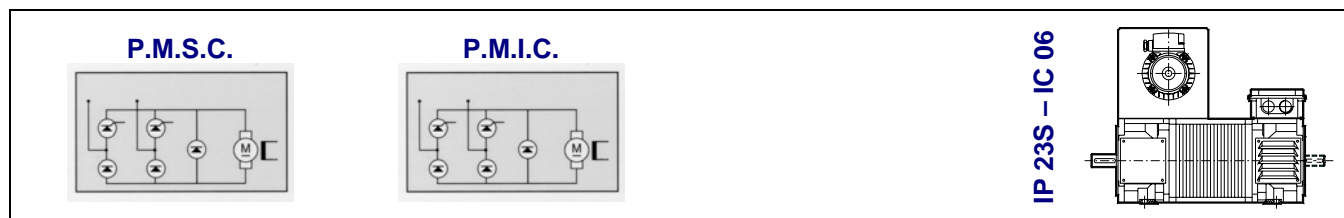

80SA QCCAS	Peso Weight	20,8 Kg				Inerzia Inertia	J 0,0042 kgm ²				Eccitazione Field	110-200-330 Vdc P 175 W K 90 ms					
	170 V				150 V				M (S1)	I Max. 15"-5'	Arm. max.	N max.	Ind. L	Res. 115°C	Cod. Arm.	Spaz. Brush nr.	
	P kW	N rpm	I A	η %	P kW	N rpm	I A	η %	Nm	A	V	rpm	mH	Ω	--	nr.	
	1,82	3000	12,9	83,0	1,60	2650	13,0	82,1	5,8	19	200	3500	12	2,2	D4	2	
	1,54	2500	11,0	82,4	1,40	2200	11,0	84,8	5,9	17	210	3100	13	3,0	E2	2	
	1,32	2080	9,5	81,7	1,20	1850	9,7	82,5	6,1	14	220	2700	15	3,6	F4	2	
1,10	1660	8,3	78,0	1,00	1450	8,3	80,3	6,3	12	230	2250	30	4,8	G2	2		

80S QCCAS	Peso Weight	25,2 Kg				Inerzia Inertia	J 0,0057 kgm ²				Eccitazione Field	110-200-330 Vdc P 200 W K 110 ms					
	170 V				150 V				M (S1)	I Max. 15"-5'	Arm. max.	N max.	Ind. L	Res. 115°C	Cod. Arm.	Spaz. Brush nr.	
	P kW	N rpm	I A	η %	P kW	N rpm	I A	η %	Nm	A	V	rpm	mH	Ω	--	nr.	
	2,30	3100	15,7	86,2	2,00	2750	15,8	84,4	7,1	24	200	3600	7,2	1,1	C2	2	
	2,00	2600	14,2	82,9	1,80	2300	14,3	83,9	7,3	21	210	3200	8,5	1,7	C8	2	
	1,72	2030	12,3	82,3	1,52	1800	12,4	81,7	8,1	18	220	2600	14	2,3	D8	2	
1,40	1600	10,6	77,7	1,21	1400	10,5	76,8	8,4	16	230	2100	25	4,0	F2	2		

80M QCCAS	Peso Weight	30,0 Kg				Inerzia Inertia	J 0,0074 kgm ²				Eccitazione Field	110-200-330 Vdc P 230 W K 130 ms					
	170 V				150 V				M (S1)	I Max. 15"-5'	Arm. max.	N max.	Ind. L	Res. 115°C	Cod. Arm.	Spaz. Brush nr.	
	P kW	N rpm	I A	η %	P kW	N rpm	I A	η %	Nm	A	V	rpm	mH	Ω	--	nr.	
	3,35	3050	22,2	88,8	3,00	2700	22,4	89,3	10,5	33	200	3600	4,4	0,90	B4	2	
	3,00	2580	20,0	88,2	2,61	2270	20,1	86,6	11,1	30	210	3200	7	1,2	B8	2	
	2,42	1950	16,7	85,2	2,14	1720	16,8	84,9	11,9	25	220	2500	10	1,7	C6	2	
2,00	1620	14,6	80,6	1,80	1430	14,6	82,2	11,8	22	230	2200	16	2,5	D6	2		

80L QCCAS	Peso Weight	35,0 Kg				Inerzia Inertia	J 0,0092 kgm ²				Eccitazione Field	110-200-330 Vdc P 270 W K 150 ms					
	170 V				150 V				M (S1)	I Max. 15"-5'	Arm. max.	N max.	Ind. L	Res. 115°C	Cod. Arm.	Spaz. Brush nr.	
	P kW	N rpm	I A	η %	P kW	N rpm	I A	η %	Nm	A	V	rpm	mH	Ω	--	nr.	
	4,00	3200	26,7	88,1	3,54	2820	26,8	88,1	11,9	40	200	3700	3,0	0,70	B0	2	
	3,40	2580	23,0	87,0	3,00	2270	23,1	86,6	12,6	35	210	3200	4,9	0,90	B4	2	
	2,65	1950	18,2	85,6	2,34	1720	18,3	85,2	13,0	27	220	2500	6,5	1,4	C0	2	
2,25	1620	15,9	83,2	2,00	1420	15,9	83,9	13,3	24	230	2200	15	2,1	C8	2		

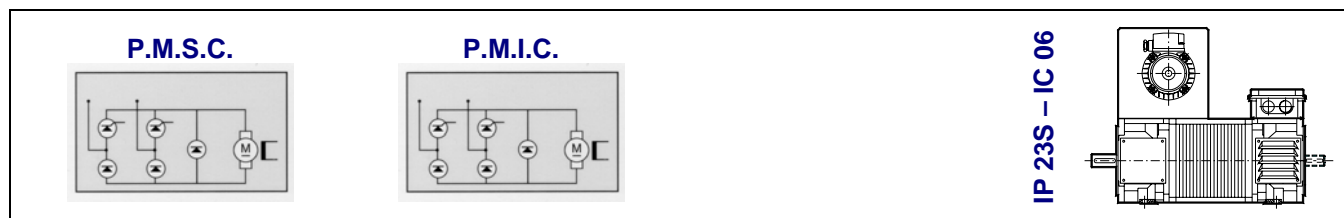

80SA QCCAS	Peso Weight	20,8 Kg				Inerzia Inertia	J 0,0042 kgm ²				Eccitazione Field		110-200-330 Vdc		P 175 W	K 90 ms
	280 V				260 V				M (S1)	I Max. 15"-5'	Arm. max.	N max.	Ind. L	Res. 115°C	Cod. Arm.	Spaz. Brush nr.
	P kW	N rpm	I A	η %	P kW	N rpm	I A	η %	Nm	A	V	rpm	mH	Ω	--	nr.
	1,87	3200	7,9	84,5	1,74	2970	8,0	83,7	5,6	12	350	4000	21	4,2	G2	2
	1,55	2500	6,6	83,9	1,44	2320	6,6	83,9	5,9	10	440	3900	35	6,0	I0	2
	1,34	2100	5,8	82,5	1,24	1950	5,8	82,2	6,1	9	480	3600	48	9,9	M0	2
	1,02	1550	4,6	79,2	0,94	1440	4,7	76,9	6,3	7	500	2800	64	15	O2	2

80S QCCAS	Peso Weight	25,2 Kg				Inerzia Inertia	J 0,0057 kgm ²				Eccitazione Field		110-200-330 Vdc		P 200 W	K 110 ms
	280 V				260 V				M (S1)	I Max. 15"-5'	Arm. max.	N max.	Ind. L	Res. 115°C	Cod. Arm.	Spaz. Brush nr.
	P kW	N rpm	I A	η %	P kW	N rpm	I A	η %	Nm	A	V	rpm	mH	Ω	--	nr.
	2,30	3100	9,5	86,5	2,1	2870	9,6	84,1	7,1	14	360	4000	17	2,8	E6	2
	2,00	2600	8,6	83,1	1,9	2410	8,6	85,0	7,3	13	440	4000	22	3,3	F8	2
	1,76	2050	7,6	82,7	1,63	1900	7,6	82,5	8,2	11	480	3500	36	5,3	G8	2
	1,42	1600	6,5	78,0	1,32	1485	6,6	76,9	8,5	10	500	2900	64	9,0	I4	2

80M QCCAS	Peso Weight	30,0 Kg				Inerzia Inertia	J 0,0074 kgm ²				Eccitazione Field		110-200-330 Vdc		P 230 W	K 130 ms
	280 V				260 V				M (S1)	I Max. 15"-5'	Arm. max.	N max.	Ind. L	Res. 115°C	Cod. Arm.	Spaz. Brush nr.
	P kW	N rpm	I A	η %	P kW	N rpm	I A	η %	Nm	A	V	rpm	mH	Ω	--	nr.
	3,38	3050	13,6	88,8	3,15	2830	13,7	88,4	10,6	20	370	4000	11	1,8	E0	2
	2,80	2450	11,4	87,7	2,6	2270	11,5	87,0	10,9	17	440	3900	16	3,4	F0	2
	2,20	1860	9,3	84,5	2,05	1730	9,3	84,8	11,3	14	480	3200	25	7,0	G4	2
	1,83	1470	8,0	81,7	1,7	1370	8,1	80,7	11,9	12	500	2600	43	13	H8	2

80L QCCAS	Peso Weight	35,0 Kg				Inerzia Inertia	J 0,0092 kgm ²				Eccitazione Field		110-200-330 Vdc		P 270 W	K 150 ms
	280 V				260 V				M (S1)	I Max. 15"-5'	Arm. max.	N max.	Ind. L	Res. 115°C	Cod. Arm.	Spaz. Brush nr.
	P kW	N rpm	I A	η %	P kW	N rpm	I A	η %	Nm	A	V	rpm	mH	Ω	--	nr.
	4,00	3200	16,1	88,7	3,73	2970	16,2	88,6	11,9	24	350	4000	11	1,5	C2	2
	3,32	2580	13,5	87,8	3,1	2400	13,6	87,7	12,3	20	440	4000	14	2,2	D0	2
	2,63	1950	10,9	86,2	2,44	1810	11,0	85,3	12,9	16	480	3350	19	3,1	E0	2
	2,23	1620	9,6	83,0	2,07	1500	9,6	82,9	13,1	14	500	2900	34	5,9	F0	2

P.T.I.C.

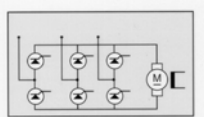

IP 23S - IC 06

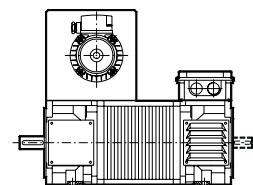

80SA QCCAS	Peso Weight	20,8 Kg				Inerzia Inertia	J 0,0042 kgm ²				Eccitazione Field	110-200-330 Vdc P 175 W K 90 ms					
	440 V				400 V				M (S1)	I Max. 15''-5'	Arm. max.	N max.	Ind. L	Res. 115°C	Cod. Arm.	Spaz. Brush nr.	
	P kW	N rpm	I A	η %	P kW	N rpm	I A	η %	Nm	A	V	rpm	mH	Ω	--	nr.	
	2,61	3240	7,2	82,4	2,37	2950	7,3	81,2	7,7	11	460	3400	48	9,9	M0	2	
	2,36	2660	6,6	81,3	2,15	2420	6,7	80,2	8,5	10	480	2900	64	15	O2	2	
	1,91	2080	5,4	80,4	1,74	1890	5,4	80,6	8,8	8	500	2350	110	21	S6	2	
1,45	1530	4,3	76,6	1,33	1400	4,3	77,3	9,1	6	500	1750	164	30	Z4	2		

80S QCCAS	Peso Weight	25,2 Kg				Inerzia Inertia	J 0,0057 kgm ²				Eccitazione Field	110-200-330 Vdc P 200 W K 110 ms					
	440 V				400 V				M (S1)	I Max. 15''-5'	Arm. max.	N max.	Ind. L	Res. 115°C	Cod. Arm.	Spaz. Brush nr.	
	P kW	N rpm	I A	η %	P kW	N rpm	I A	η %	Nm	A	V	rpm	mH	Ω	--	nr.	
	4,00	3300	10,7	85,0	3,64	3000	10,8	84,3	11,6	16	460	3450	36	5,3	G8	2	
	3,45	2760	9,5	82,5	3,1	2500	9,5	81,6	11,9	14	480	3000	48	7,9	I4	2	
	2,68	2100	7,5	81,2	2,42	1900	7,5	80,7	12,2	11	500	2400	85	14	N4	2	
2,10	1580	6,0	79,5	1,9	1440	6,0	79,2	12,7	9	500	1800	130	21	R4	2		

80M QCCAS	Peso Weight	30,0 Kg				Inerzia Inertia	J 0,0074 kgm ²				Eccitazione Field	110-200-330 Vdc P 230 W K 130 ms					
	440 V				400 V				M (S1)	I Max. 15''-5'	Arm. max.	N max.	Ind. L	Res. 115°C	Cod. Arm.	Spaz. Brush nr.	
	P kW	N rpm	I A	η %	P kW	N rpm	I A	η %	Nm	A	V	rpm	mH	Ω	--	nr.	
	4,70	3140	12,1	88,3	4,26	2850	12,2	87,3	14,3	18	460	3300	29	4,6	F4	2	
	3,72	2420	9,8	86,3	3,38	2200	9,9	85,4	14,7	15	480	2640	40	5,5	G8	2	
	3,30	2030	9,0	83,3	3,00	1850	9,0	83,3	15,5	14	500	2300	64	9,0	I4	2	
2,48	1510	6,9	81,7	2,25	1370	7,0	80,4	15,7	10	500	1700	110	16	M8	2		

80L QCCAS	Peso Weight	35,0 Kg				Inerzia Inertia	J 0,0092 kgm ²				Eccitazione Field	110-200-330 Vdc P 270 W K 150 ms					
	440 V				400 V				M (S1)	I Max. 15''-5'	Arm. max.	N max.	Ind. L	Res. 115°C	Cod. Arm.	Spaz. Brush nr.	
	P kW	N rpm	I A	η %	P kW	N rpm	I A	η %	Nm	A	V	rpm	mH	Ω	--	nr.	
	5,67	3080	14,5	88,9	5,16	2800	14,6	88,4	17,6	22	460	3250	19	3,1	E0	2	
	4,92	2630	12,7	88,0	4,5	2400	12,9	87,2	17,9	19	480	2900	34	4,0	F0	2	
	4,00	2100	10,5	86,6	3,62	1900	10,6	85,4	18,2	16	500	2400	51	6,5	G8	2	
2,95	1520	7,8	86,0	2,67	1380	7,9	84,5	18,5	12	500	1730	83	12	L8	2		

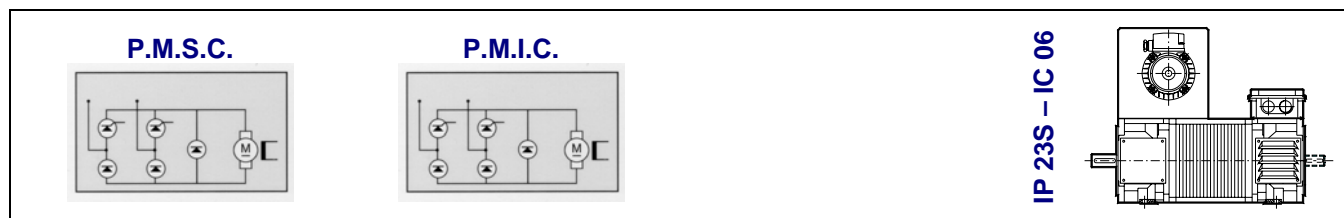

100SA QCCAS	Peso Weight	47,0 Kg				Inerzia Inertia	J 0,017 kgm ²				Eccitazione Field	110-200-330 Vdc P 260 W K 130 ms					
	170 V				150 V				M (S1)	I Max. 15"-5'	Arm. max.	N max.	Ind. L	Res. 115°C	Cod. Arm.	Spaz. Brush nr.	
	P kW	N rpm	I A	η %	P kW	N rpm	I A	η %	Nm	A	V	rpm	mH	Ω	--	nr.	
	4,8	3060	34,2	82,6	4,2	2700	34,4	82,2	15,0	51	220	4000	2,4	0,30	A6	4	
	3,9	2450	28,1	82,1	3,5	2150	28,3	81,5	15,3	42	270	4000	3,5	0,60	B0	4	
	3,5	2100	25,0	81,2	3,0	1850	25,1	80,7	15,7	38	320	4000	6,4	1,1	B4	2	
2,4	1450	18,1	79,3	2,2	1300	18,2	78,8	16,1	27	440	3750	12	1,7	C4	2		

100S QCCAS	Peso Weight	52,0 Kg				Inerzia Inertia	J 0,021 kgm ²				Eccitazione Field	110-200-330 Vdc P 310 W K 160 ms					
	170 V				150 V				M (S1)	I Max. 15"-5'	Arm. max.	N max.	Ind. L	Res. 115°C	Cod. Arm.	Spaz. Brush nr.	
	P kW	N rpm	I A	η %	P kW	N rpm	I A	η %	Nm	A	V	rpm	mH	Ω	--	nr.	
	5,7	3000	39,1	85,0	5,0	2650	39,5	84,4	18,0	59	225	4000	2,0	0,25	A4	4	
	5,0	2600	35,4	83,1	4,5	2300	35,6	83,5	18,4	53	260	4000	3,1	0,55	A6	4	
	3,9	1900	27,6	82,1	3,4	1680	27,9	81,2	19,4	41	350	4000	4,4	0,90	B2	4	
3,3	1550	23,9	80,2	2,9	1370	24,2	79,1	20,1	36	440	4000	8,8	1,1	B6	2		

100M QCCAS	Peso Weight	67,5 Kg				Inerzia Inertia	J 0,030 kgm ²				Eccitazione Field	110-200-330 Vdc P 330 W K 190 ms					
	170 V				150 V				M (S1)	I Max. 15"-5'	Arm. max.	N max.	Ind. L	Res. 115°C	Cod. Arm.	Spaz. Brush nr.	
	P kW	N rpm	I A	η %	P kW	N rpm	I A	η %	Nm	A	V	rpm	mH	Ω	--	nr.	
	6,8	2500	45,8	87,3	6,0	2200	45,9	86,9	26,0	69	270	4000	2,9	0,50	A2	4	
	5,3	1900	36,4	86,1	4,7	1680	36,8	85,1	26,8	55	360	4000	4,4	0,80	A6	4	
	4,5	1560	31,1	84,5	3,9	1380	31,5	83,4	27,4	47	440	4000	8,0	1,0	B0	4	

100L QCCAS	Peso Weight	77,5 Kg				Inerzia Inertia	J 0,040 kgm ²				Eccitazione Field	110-200-330 Vdc P 360 W K 210 ms					
	170 V				150 V				M (S1)	I Max. 15"-5'	Arm. max.	N max.	Ind. L	Res. 115°C	Cod. Arm.	Spaz. Brush nr.	
	P kW	N rpm	I A	η %	P kW	N rpm	I A	η %	Nm	A	V	rpm	mH	Ω	--	nr.	
	6,7	2000	44,6	88,4	5,9	1770	45,0	87,6	32,0	67	340	4000	3,5	0,30	A2	4	
	5,8	1700	39,3	87,1	5,1	1500	39,8	85,9	32,7	59	400	4000	4,2	0,50	A4	4	
	5,3	1500	36,7	84,9	4,7	1330	37,1	84,1	33,7	55	440	3900	6,0	0,90	A6	4	

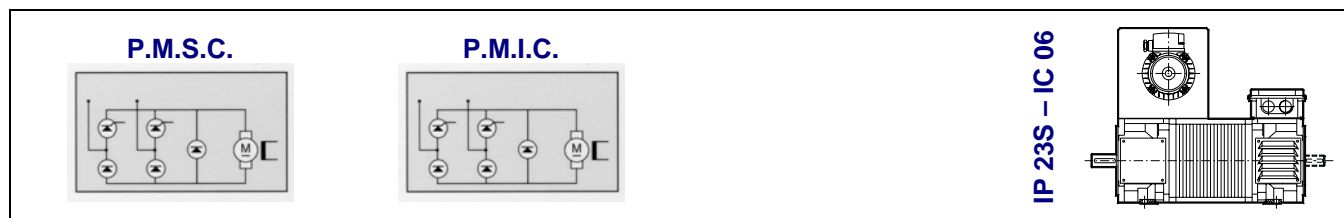

100SA QCCAS	Peso Weight	47,0 Kg	Inerzia Inertia	J 0,017 kgm ²	Eccitazione Field	110-200-330 Vdc	P 280 W	K 130 ms													
	280 V				260 V				M (S1)	I Max. 15"-5'	Arm. max.	N max.	Ind. L	Res. 115°C	Cod. Arm.	Spaz. Brush nr.					
	P kW	N rpm	I A	η %	P kW	N rpm	I A	η %	Nm	A	V	rpm	mH	Ω	--	nr.					
	4,9	3250	20,3	85,5	4,5	3020	20,4	85,0	14,3	30	340	4000	8,0	1,2	B8	2					
	3,9	2550	16,5	84,8	3,6	2370	16,6	84,3	14,7	25	440	4000	12	1,7	C4	2					

100S QCCAS	Peso Weight	52,0 Kg	Inerzia Inertia	J 0,021 kgm ²	Eccitazione Field	110-200-330 Vdc	P 310 W	K 160 ms													
	280 V				260 V				M (S1)	I Max. 15"-5'	Arm. max.	N max.	Ind. L	Res. 115°C	Cod. Arm.	Spaz. Brush nr.					
	P kW	N rpm	I A	η %	P kW	N rpm	I A	η %	Nm	A	V	rpm	mH	Ω	--	nr.					
	6,5	3270	27,0	86,0	6,1	3050	27,1	85,9	19,0	41	340	4000	4,4	0,90	B2	4					
	5,5	2670	23,1	85,0	5,1	2480	23,4	84,0	19,7	35	420	4000	8,8	1,1	B6	2					

100M QCCAS	Peso Weight	67,5 Kg	Inerzia Inertia	J 0,030 kgm ²	Eccitazione Field	110-200-330 Vdc	P 330 W	K 190 ms													
	280 V				260 V				M (S1)	I Max. 15"-5'	Arm. max.	N max.	Ind. L	Res. 115°C	Cod. Arm.	Spaz. Brush nr.					
	P kW	N rpm	I A	η %	P kW	N rpm	I A	η %	Nm	A	V	rpm	mH	Ω	--	nr.					
	9,0	3250	36,8	87,3	8,3	3020	37,0	86,3	26,4	55	340	4000	3,5	0,70	A6	4					
	7,6	2680	31,1	86,9	7,0	2490	31,3	86,0	27,0	47	420	4000	5,7	1,0	B0	4					

100L QCCAS	Peso Weight	77,5 Kg	Inerzia Inertia	J 0,040 kgm ²	Eccitazione Field	110-200-330 Vdc	P 360 W	K 210 ms													
	280 V				260 V				M (S1)	I Max. 15"-5'	Arm. max.	N max.	Ind. L	Res. 115°C	Cod. Arm.	Spaz. Brush nr.					
	P kW	N rpm	I A	η %	P kW	N rpm	I A	η %	Nm	A	V	rpm	mH	Ω	--	nr.					
	9,9	2900	39,8	89,0	9,2	2700	40,0	88,7	32,7	60	380	4000	4,2	0,50	A4	4					
	8,6	2500	35,0	88,1	8,1	2320	35,3	88,3	33,0	53	440	4000	5,5	0,70	A6	4					

P.T.I.C.

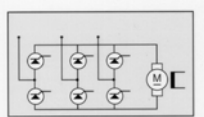

IP 23S - IC 06

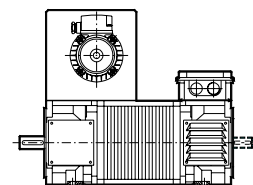

100SA QCCAS	Peso Weight	47,0 Kg				Inerzia Inertia	J 0,017 kgm ²				Eccitazione Field	110-200-330 Vdc P 280 W K 130 ms					
	440 V				400 V				M (S1)	I Max. 15"-5'	Arm. max.	N max.	Ind. L	Res. 115°C	Cod. Arm.	Spaz. Brush nr.	
	P kW	N rpm	I A	η %	P kW	N rpm	I A	η %	Nm	A	V	rpm	mH	Ω	--	nr.	
	6,5	3080	17,0	86,2	5,9	2800	17,2	85,2	20,0	26	480	3400	21	3,0	D6	2	
	5,9	2600	15,7	85,1	5,3	2370	15,8	84,5	21,6	24	480	2900	27	3,7	E2	2	
	4,8	2100	13,0	84,4	4,4	1900	13,1	84,0	22,0	20	500	2400	43	5,7	F4	2	
	3,8	1600	10,5	81,2	3,4	1450	10,6	80,2	22,4	16	500	1800	80	9,0	H4	2	

100S QCCAS	Peso Weight	52,0 Kg				Inerzia Inertia	J 0,021 kgm ²				Eccitazione Field	110-200-330 Vdc P 310 W K 160 ms					
	440 V				400 V				M (S1)	I Max. 15"-5'	Arm. max.	N max.	Ind. L	Res. 115°C	Cod. Arm.	Spaz. Brush nr.	
	P kW	N rpm	I A	η %	P kW	N rpm	I A	η %	Nm	A	V	rpm	mH	Ω	--	nr.	
	9,6	3360	24,7	88,3	8,7	3050	24,9	87,7	27,3	37	480	3600	15	1,9	C4	2	
	7,6	2600	19,8	87,2	6,9	2370	20,0	86,3	27,9	30	480	2850	18	2,8	D2	2	
	6,3	2100	16,6	85,7	5,7	1900	16,7	85,3	28,5	25	500	2400	29	3,9	E2	2	
	4,9	1600	13,3	83,2	4,3	1450	13,5	80,0	29,1	20	500	1800	56	6,5	F8	2	

100M QCCAS	Peso Weight	67,5 Kg				Inerzia Inertia	J 0,030 kgm ²				Eccitazione Field	110-200-330 Vdc P 330 W K 190 ms					
	440 V				400 V				M (S1)	I Max. 15"-5'	Arm. max.	N max.	Ind. L	Res. 115°C	Cod. Arm.	Spaz. Brush nr.	
	P kW	N rpm	I A	η %	P kW	N rpm	I A	η %	Nm	A	V	rpm	mH	Ω	--	nr.	
	11,7	3230	29,6	89,5	10,6	2950	29,7	89,2	34,5	44	480	3500	8,9	1,3	B6	4	
	9,7	2640	24,9	88,8	8,8	2400	25,1	88,0	35,2	37	480	2900	16	1,9	C2	2	
	7,9	2100	20,4	88,1	7,2	1900	20,5	87,7	36,0	31	500	2400	25	3,0	D0	2	
	6,3	1600	16,6	86,8	5,8	1450	16,7	86,4	37,8	25	500	1800	42	5,2	D6	2	

100L QCCAS	Peso Weight	77,5 Kg				Inerzia Inertia	J 0,040 kgm ²				Eccitazione Field	110-200-330 Vdc P 360 W K 210 ms					
	440 V				400 V				M (S1)	I Max. 15"-5'	Arm. max.	N max.	Ind. L	Res. 115°C	Cod. Arm.	Spaz. Brush nr.	
	P kW	N rpm	I A	η %	P kW	N rpm	I A	η %	Nm	A	V	rpm	mH	Ω	--	nr.	
	14,6	3150	36,4	91,2	13,3	2870	36,6	90,5	44,3	55	480	3500	7,5	0,90	B0	4	
	12,3	2600	30,9	90,1	11,1	2370	31,1	89,5	45,0	46	480	2900	11	1,3	B4	4	
	9,8	2050	25,2	88,7	8,9	1860	25,3	88,2	45,8	38	500	2400	19	1,9	C0	2	
	7,6	1550	19,6	88,2	6,9	1410	19,8	87,4	46,9	29	500	1800	32	4,0	D0	2	

P.T.I.C.

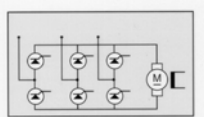

IP 23S - IC 06

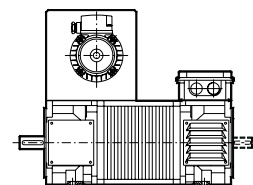

132SA QCCAS	Peso Weight	110 Kg				Inerzia Inertia	J 0,060 kgm ²				Eccitazione Field	110-200-330 Vdc P 450 W K 160 ms					
	440 V				400 V				M (S1)	I Max. 15"-5'	Arm. max.	N max.	Ind. L	Res. 115°C	Cod. Arm.	Spaz. Brush	
	P kW	N rpm	I A	η %	P kW	N rpm	I A	η %	Nm	A	V	rpm	mH	Ω	--	nr.	
	21	3300	53	90,1	19	3000	53	89,1	61	80	460	3500	3,3	0,31	A6	4	
	19	3000	48	90,9	17	2700	48	89,5	60	71	460	3500	4,5	0,43	A8	4	
	17	2700	43	89,9	15,5	2450	44	89,1	60	65	460	3000	5,3	0,58	B0	4	
	15	2450	38	89,7	14	2200	39	89,7	58	57	500	3000	7,0	0,73	B2	4	
	13	2000	33	89,5	12	1800	34	88,2	62	50	500	2500	12	1,25	B6	4	
10	1500	26	87,4	9	1350	26	86,5	64	39	520	2000	21	2,20	C4	4		
6,5	1000	17	86,9	6	930	18	85,7	62	26	520	1500	36	3,80	E0	4		

132S QCCAS	Peso Weight	133 Kg				Inerzia Inertia	J 0,075 kgm ²				Eccitazione Field	110-200-330 Vdc P 580 W K 170 ms					
	440 V				400 V				M (S1)	I Max. 15"-5'	Arm. max.	N max.	Ind. L	Res. 115°C	Cod. Arm.	Spaz. Brush	
	P kW	N rpm	I A	η %	P kW	N rpm	I A	η %	Nm	A	V	rpm	mH	Ω	--	nr.	
	30	3300	75	90,9	27,5	3000	76	90,5	87	113	460	3500	2,3	0,24	A2	8	
	26	2800	65	90,9	24	2500	66	90,9	89	98	460	3500	3,4	0,36	A4	8	
	24	2500	61	89,4	22	2300	62	89,1	92	92	500	3000	4,5	0,45	A6	8	
	19	2000	49	88,1	17	1800	49	86,7	91	74	500	2500	7,0	0,73	B0	4	
	14	1500	36	88,4	12,6	1350	37	86,3	89	54	520	2000	12	1,27	B6	4	
9,8	1000	26	86,3	9	900	26	85,6	94	39	520	1500	20	2,24	C8	4		

132M QCCAS	Peso Weight	155 Kg				Inerzia Inertia	J 0,095 kgm ²				Eccitazione Field	110-200-330 Vdc P 700 W K 180 ms					
	440 V				400 V				M (S1)	I Max. 15"-5'	Arm. max.	N max.	Ind. L	Res. 115°C	Cod. Arm.	Spaz. Brush	
	P kW	N rpm	I A	η %	P kW	N rpm	I A	η %	Nm	A	V	rpm	mH	Ω	--	nr.	
	--	--	--	--	39	3200	109	89,4	116	150	460	3500	2,1	0,19	8	8	
	35	2900	89	89,4	32	2650	90	89,1	115	134	460	3500	2,4	0,22	A0	8	
	31	2450	80	88,1	28	2200	80	87,5	121	120	500	3000	3,4	0,30	A2	8	
	27	2100	69	88,9	24,5	1900	70	88,1	123	104	500	2500	4,6	0,43	A4	8	
	21	1600	55	86,8	19	1450	55	86,2	125	83	520	2000	7,6	0,70	A8	4	
12,8	1000	33	87,1	11,5	900	34	85,8	122	50	520	1500	18	1,77	B8	4		

132L QCCAS	Peso Weight	180 Kg				Inerzia Inertia	J 0,120 kgm ²				Eccitazione Field	110-200-330 Vdc P 820 W K 190 ms					
	440 V				400 V				M (S1)	I Max. 15"-5'	Arm. max.	N max.	Ind. L	Res. 115°C	Cod. Arm.	Spaz. Brush	
	P kW	N rpm	I A	η %	P kW	N rpm	I A	η %	Nm	A	V	rpm	mH	Ω	--	nr.	
	45	3000	113	90,5	41	2700	114	90,1	143	170	460	3500	1,9	0,16	8	8	
	35,5	2350	89	90,7	32	2100	89	89,9	144	134	500	3000	3,0	0,25	A0	8	
	29,5	1950	77	87,1	27	1750	78	87,1	144	116	500	2500	4,2	0,35	A2	8	
	22	1450	57	87,7	20	1300	58	87,0	145	86	520	2000	7,6	0,65	A6	8	
	16	1050	42	86,6	14,5	930	42	85,9	146	63	520	1500	14	1,28	B2	4	

P.T.I.C.

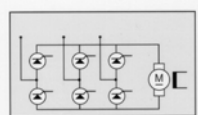

IP 23S - IC 06

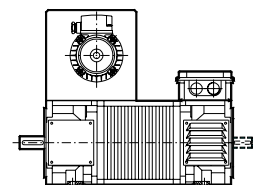

160SB QCCAS	Peso Weight	215 Kg				Inerzia Inertia	J 0,21 kgm ²				Eccitazione Field	110-200-330 Vdc P 820 W K 240 ms					
	440 V				400 V				M (S1)	I Max. 15"-5'	Arm. max.	N max.	Ind. L	Res. 115°C	Cod. Arm.	Spaz. Brush nr.	
	P kW	N rpm	I A	η %	P kW	N rpm	I A	η %	Nm	A	V	rpm	mH	Ω	--	nr.	
	52,5	3000	133	89,7	48	2700	134	89,9	167	180	460	3500	1,9	0,15	8	8	
	44	2400	111	90,1	40,5	2200	112	90,4	175	166	460	3000	3,0	0,22	A0	8	
	35	1900	89	89,9	31,5	1700	89	88,5	176	133	500	2500	4,4	0,35	A2	8	
	29	1500	74	89,1	26	1350	74	87,8	184	111	520	2000	5,9	0,48	A6	4	
21	1050	54	88,4	19	950	54	88,0	191	81	520	1500	14	1,05	B2	4		

160M QCCAS	Peso Weight	250 Kg				Inerzia Inertia	J 0,24 kgm ²				Eccitazione Field	110-200-330 Vdc P 950 W K 290 ms					
	440 V				400 V				M (S1)	I Max. 15"-5'	Arm. max.	N max.	Ind. L	Res. 115°C	Cod. Arm.	Spaz. Brush nr.	
	P kW	N rpm	I A	η %	P kW	N rpm	I A	η %	Nm	A	V	rpm	mH	Ω	--	nr.	
	70	3100	174	91,4	63,5	2800	175	91,0	215	230	460	3500	1,4	0,10	6	8	
	55	2300	138	90,6	50	2100	139	89,9	228	207	460	3000	2,2	0,18	8	8	
	45	1850	114	90,1	40,5	1650	113	89,6	232	170	500	2500	3,6	0,26	A0	8	
	39	1550	99	89,5	35,5	1400	100	89,1	240	148	520	2000	5,1	0,38	A2	8	
27	1050	70	87,7	24,5	950	71	86,9	245	105	520	1500	9,3	0,65	A8	4		

160L QCCAS	Peso Weight	280 Kg				Inerzia Inertia	J 0,29 kgm ²				Eccitazione Field	110-200-330 Vdc P 1150 W K 350 ms					
	440 V				400 V				M (S1)	I Max. 15"-5'	Arm. max.	N max.	Ind. L	Res. 115°C	Cod. Arm.	Spaz. Brush nr.	
	P kW	N rpm	I A	η %	P kW	N rpm	I A	η %	Nm	A	V	rpm	mH	Ω	--	nr.	
	72	2500	178	91,9	65	2250	178	91,3	275	230	460	3000	1,7	0,12	6	8	
	55,5	1850	138	91,4	51	1700	140	91,1	286	207	500	2500	2,7	0,20	8	8	
	44	1450	110	90,9	40	1300	111	90,1	290	165	500	2000	4,2	0,30	A0	8	
	31	1000	80	88,1	28	900	80	87,5	296	120	520	1500	8,0	0,57	A4	8	

160P QCCAS	Peso Weight	317 Kg				Inerzia Inertia	J 0,32 kgm ²				Eccitazione Field	110-200-330 Vdc P 1300 W K 390 ms					
	440 V				400 V				M (S1)	I Max. 15"-5'	Arm. max.	N max.	Ind. L	Res. 115°C	Cod. Arm.	Spaz. Brush nr.	
	P kW	N rpm	I A	η %	P kW	N rpm	I A	η %	Nm	A	V	rpm	mH	Ω	--	nr.	
	70	2000	172	92,5	63,5	1800	173	92,0	334	230	460	2500	1,7	0,13	6	8	
	53	1500	131	92,0	48	1350	131	91,4	337	196	500	2000	3,0	0,22	8	8	
	42,5	1200	107	90,3	40	1100	110	90,9	338	160	500	2000	4,6	0,33	A0	8	
	36	1000	92	88,9	32,5	900	93	87,8	344	138	520	1500	6,6	0,50	A2	8	

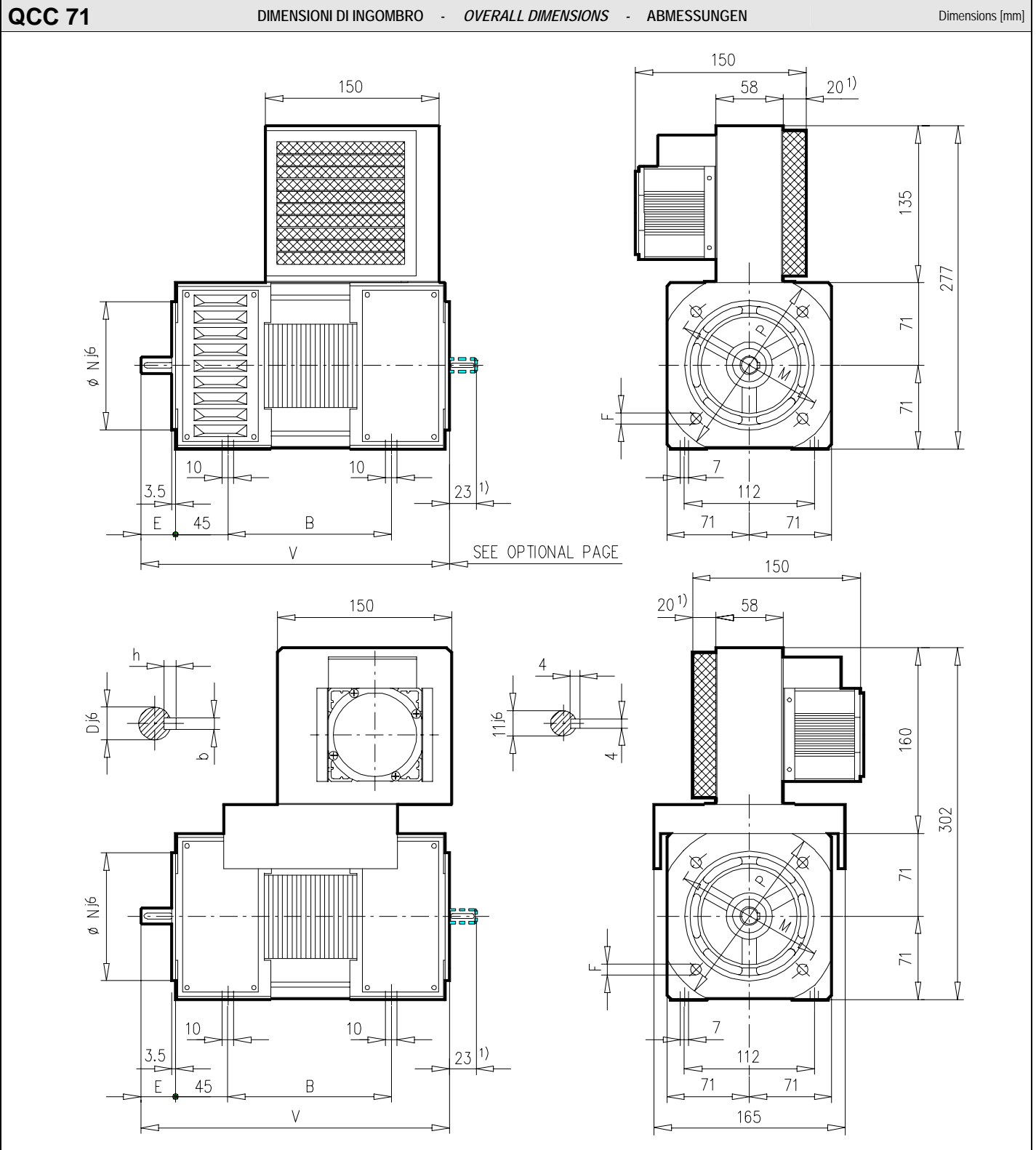

Type	B	D x E	b x h	M	N	P	F	V
71 S	101							230
71 M	121	14x30	5x5	130	110	160	10	250
71 L	141							270
71 P	181							320
71 P ¹⁾	--	19x40	6x6	165	130	200	11.5	

1) OPTIONAL

QCC 80 - 100

DIMENSIONI DI INGOMBRO - OVERALL DIMENSIONS - ABMESSUNGEN

Dimensions [mm]

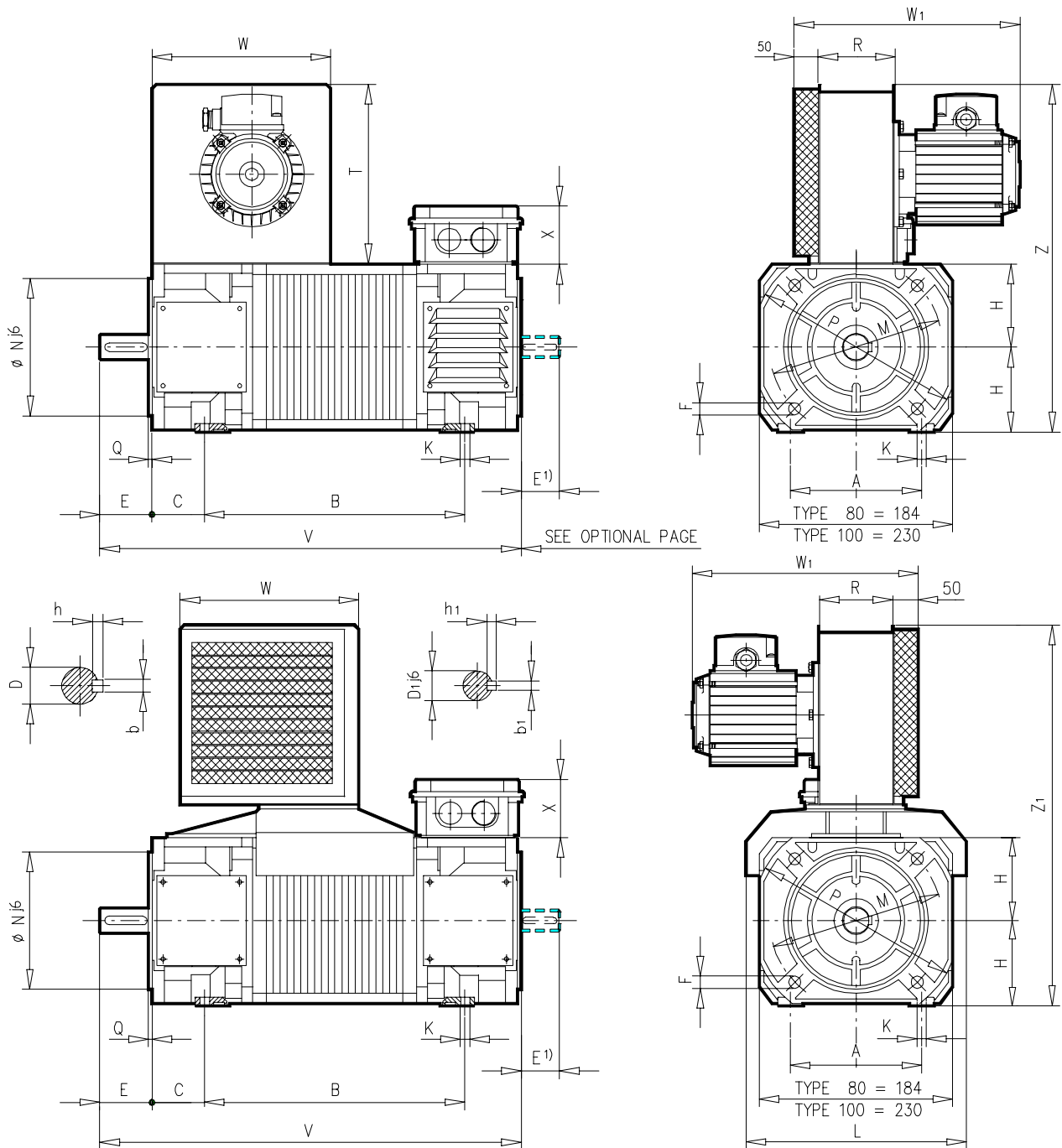

Type	H	A	B	C	K	D x E	D ₁ x E ₁	b x h	b ₁ x h ₁	M	N	Q	P	F	V	Z	Z ₁	W	W ₁	T	R	L	X	
80 SA			173												327									
80 S	80	125	198	50	9	24x50				165	130	3.5	200	11.5	352									
80 M			223				19x40		6x6						377	330	370	170	240	172	72	210	55	
80 L			248					8x7							402									
80 M ¹⁾															387									
80 L ¹⁾															412									
100 SA			241			28x60									433									
100 S	100	160	261	63	12					215	180		250		453									
100 M			301									4		14	513									
100 L			348			28x60		8x7							560	395	432	215	310	195	87	268	67	
100 M ¹⁾						38x80		10x8							513									
100 L ¹⁾										265	230		300		560									

¹⁾ OPTIONAL

QCC 132 - 160

DIMENSIONI DI INGOMBRO - OVERALL DIMENSIONS - ABMESSUNGEN

Dimensions [mm]

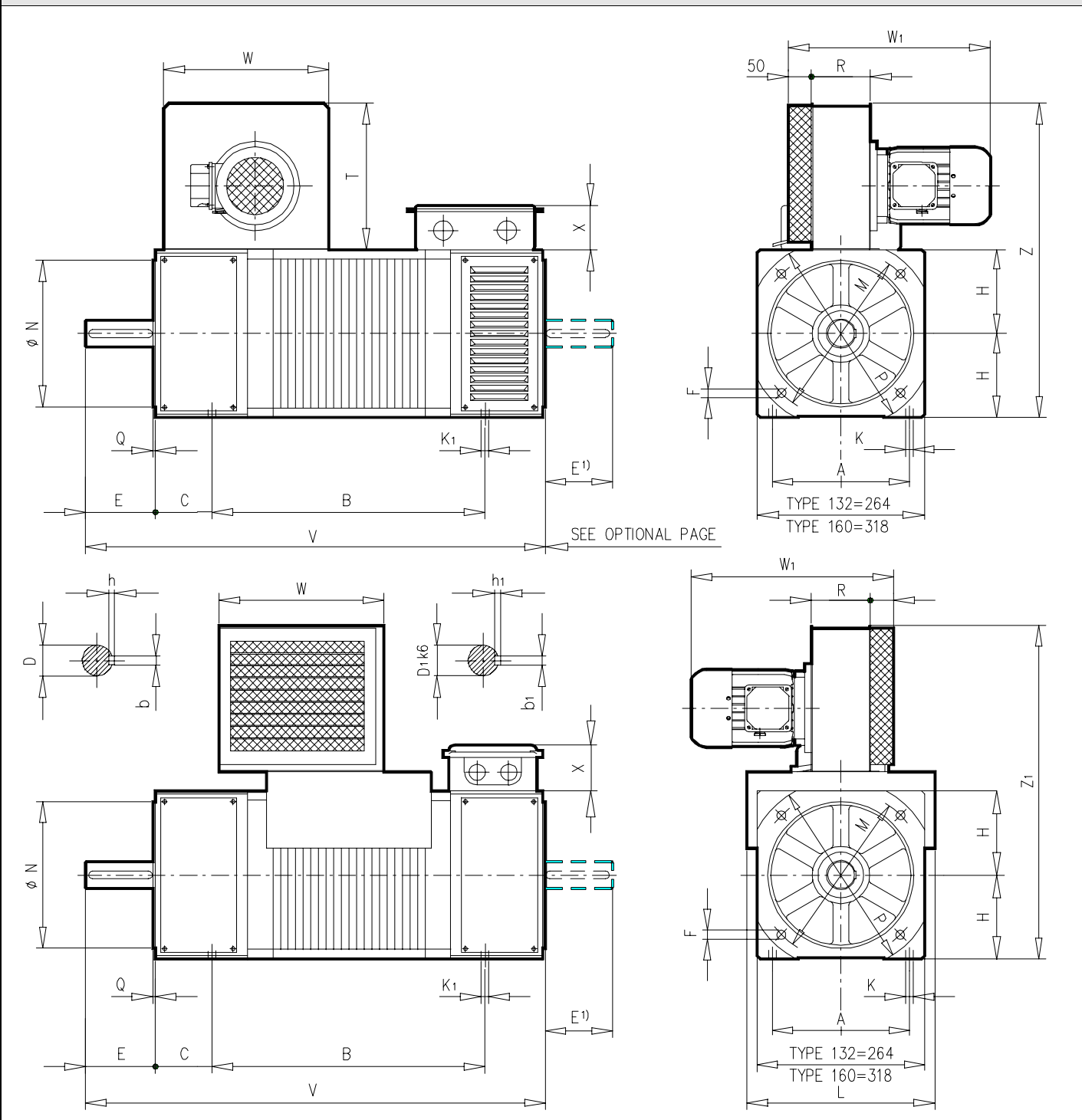

Type	H	A	B	C	K	K ₁	D x E	D ₁ x E ₁	b x h	b ₁ x h ₁	M	N	Q	P	F	V	Z	Z ₁	W	W ₁	T	R	L	X	
132 SA			292													584									
132 S	132	216	332	89	12	12	42x110	42x110	12x8	12x8	265	230	4	300	14	624	494	524	260	340	230	93	296	70	
132 M			382													674									
132 L			432													724									
160 SB			342													724									
160 M	160	254	392	108	14	--	48x110	42x110	14x9	12x8	300	250	5	350	18	774	600	630	315	420	280	123	362	102	
160 L			442													824									
160 P			492													874									

¹⁾ OPTIONAL
 Su richiesta è disponibile un elettroventilatore maggiorato - An increased power electric fan is available on request - Auf Anfrage sind leistungsstärkere Elektrolüfter verfügbar

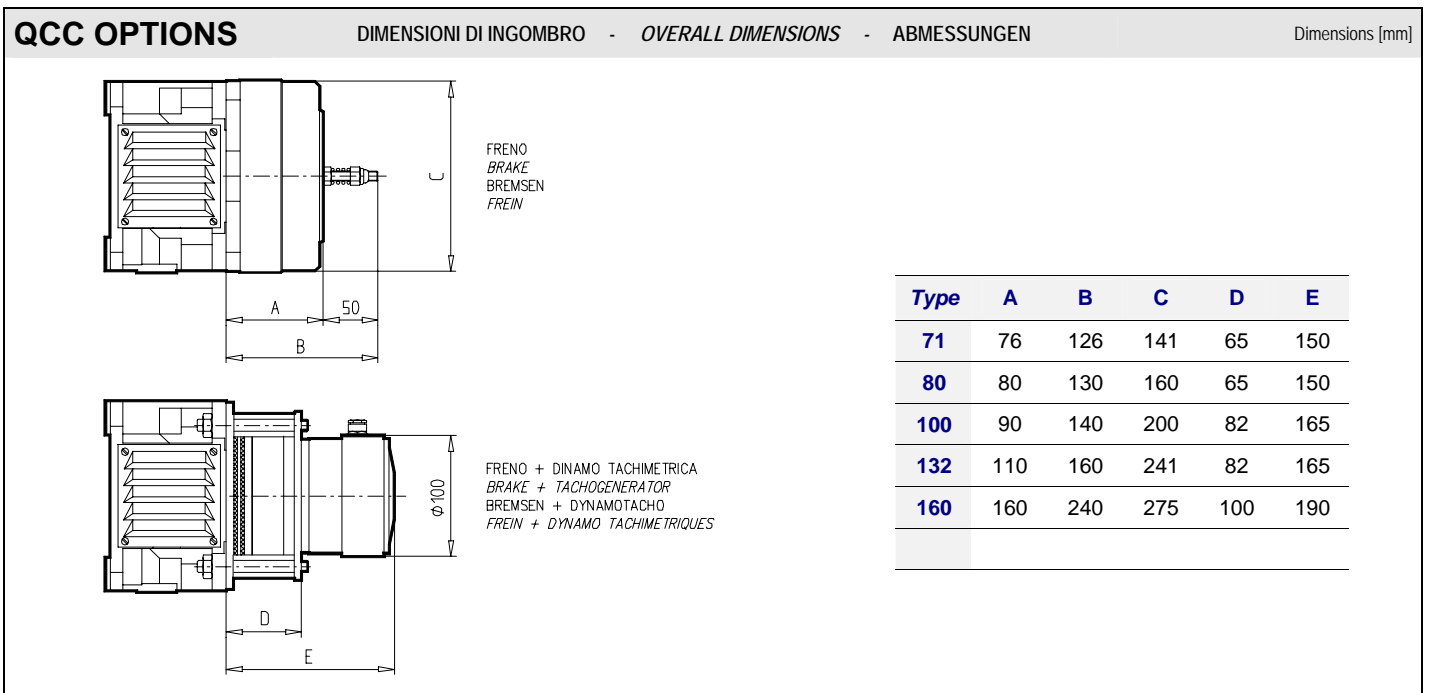
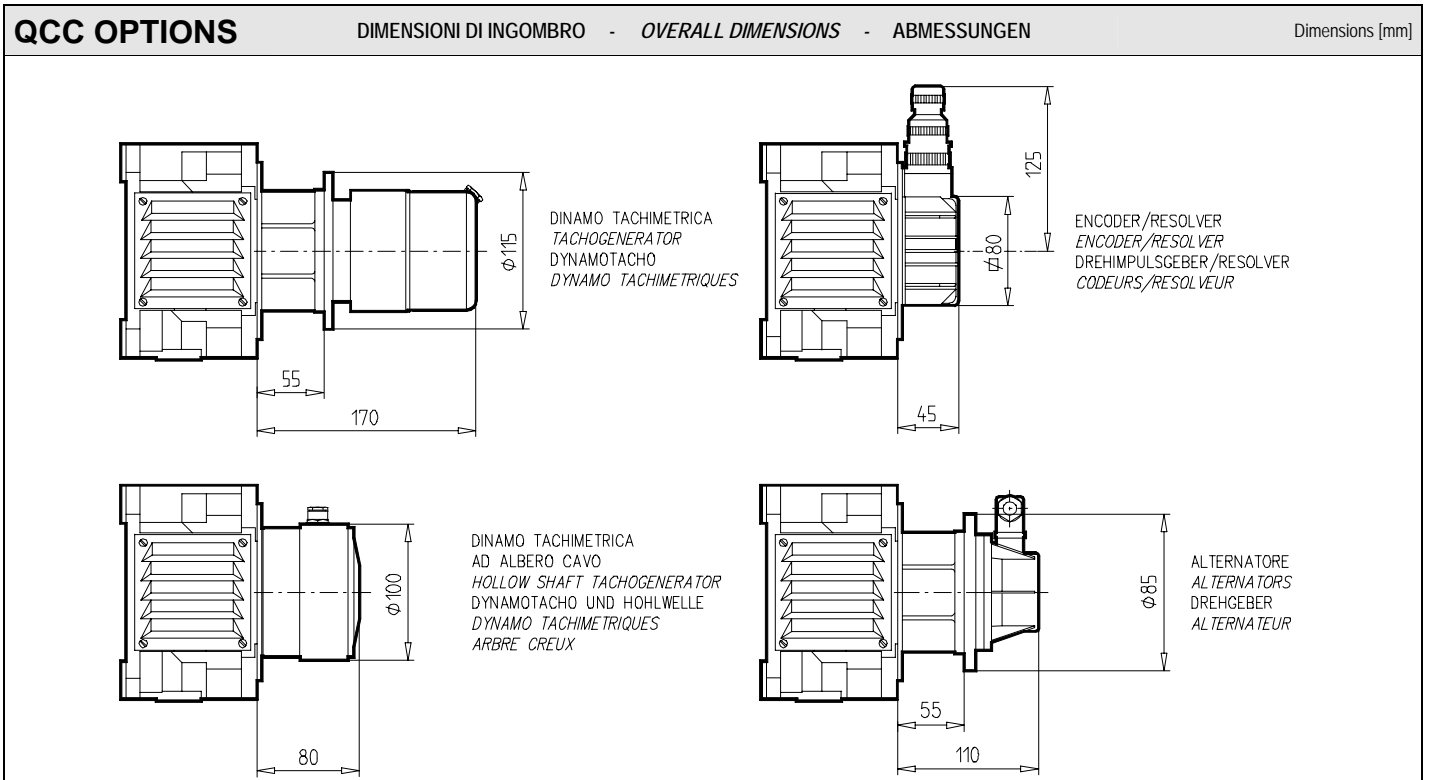

Note

Il presente catalogo tecnico è formato da una parte introduttiva che fornisce informazioni generali relative a tutte le grandezze di motori e da schede tecniche specifiche per ogni singolo tipo. E' necessario consultare entrambe le sezioni per ottenere informazioni complete e corrette.

Ci riserviamo di modificare in qualsiasi momento e senza preavviso i dati, le caratteristiche tecniche, le dimensioni, i pesi e le illustrazioni.

La riproduzione anche parziale, del presente catalogo deve essere autorizzata per iscritto dalla OEMER S.p.A.. OEMER motori elettrici S.p.A., Diritti riservati.

Note

The present technical catalog is composed by an introductory part giving general information about all sizes of motors and by specific technical sheets for each single motor. It is necessary to consult both sections in order to obtain complete and correct information.

We reserve the right to modify at any time and without notice the data, the technical characteristics, the dimensions, the weights and the illustrations.

The reproduction, even in part, of the present catalog must be authorized in writing by OEMER SpA. OEMER motori elettrici S.p.A.. All rights reserved.

Hinweise

Dieser technische Katalog besteht aus einem einführenden Teil (hier befinden sich die allgemeinen Angaben über alle Motorengrößen) u. aus speziellen Datenblättern für jeden einzelnen Motortyp. Es ist jedoch notwendig in beiden Abschnitte nachzuschauen, um über vollständige und einwandfreie Angaben zu verfügen.

Wir behalten uns das Recht vor, ohne Vorankündigung, die Daten, technische Merkmale, Abmessungen, Gewichte und Abbildungen dieses Kataloges abzuändern.

Jegliche Vervielfältigung auch teilweise dieses Kataloges bedarf der schriftlichen Zustimmung von OEMER SpA. OEMER SpA. Alle Rechte vorbehalten.