

SL-SMP-SX

SLITTE
SLIDES
SCHLITTEN

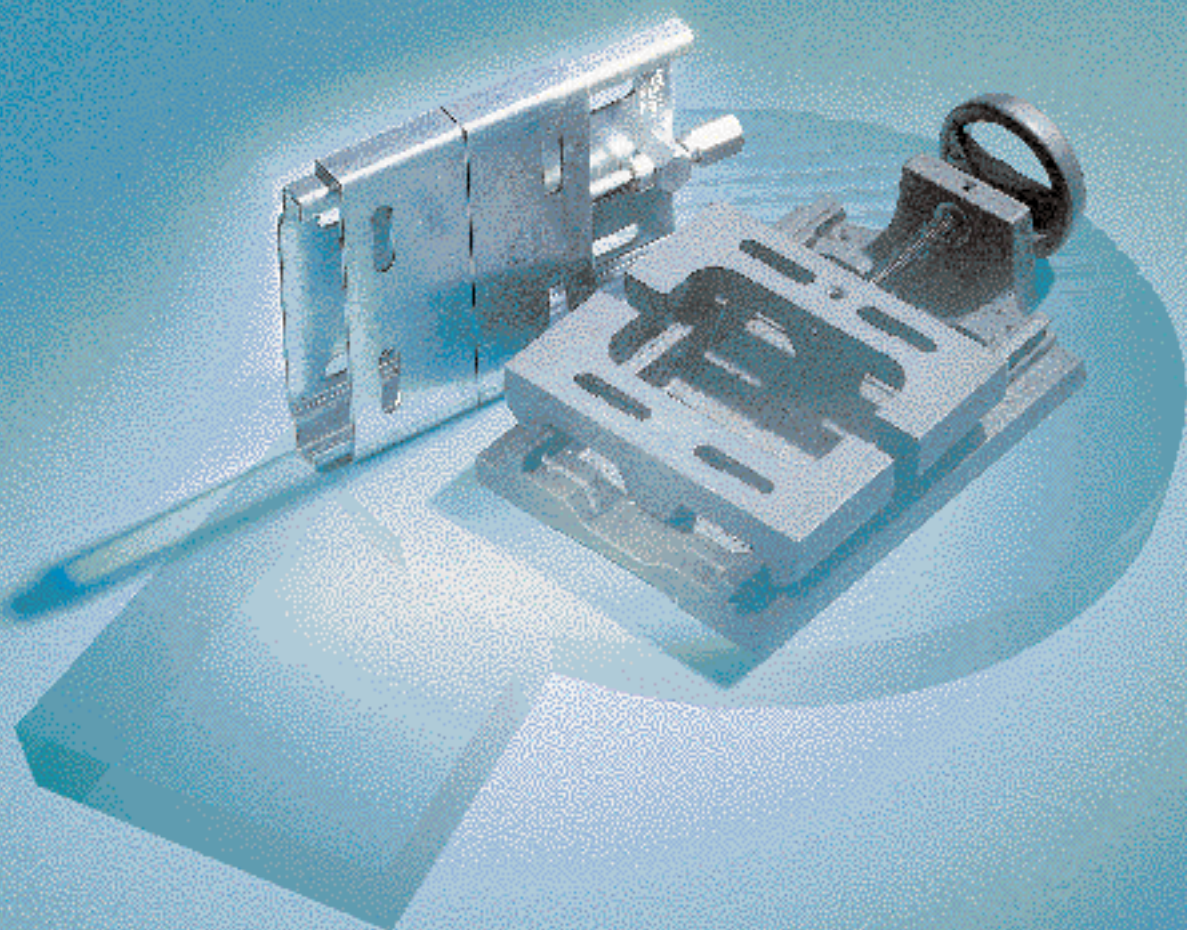

SLITTE SLIDES SCHLITTEN

È noto che, quando si affronta l'applicazione di pulegge a doppia espansione, si ottiene la variazione della velocità sull'albero in uscita agendo sull'interasse dei due alberi (motore-condotto). Le nostre slitte portamotore offrono una soluzione rapida ed economica a questo problema: le slitte SL e SMP...NS, con il corpo in ghisa, sono praticamente pronte per il montaggio del motore. Per applicazioni più leggere e compatte troviamo la serie SX: costruite in lamiera zincata non necessitano di lavorazioni supplementari (forature) per essere montate sulla macchina. Inoltre, scegliendo le slitte serie SX, si dispone di un'ampia gamma di motori a norme UNELMEC, mantenendo una quantità di corse di regolazione molto ampia.

It is common knowledge that, when dealing with the application of pulleys with double expansion, there is speed variation on the output shaft operating on the shafts centre distance. Our motor-support slides offer a rapid and cost-effective solution to this problem: the SL and SMP...NS slides, with cast iron body, are virtually ready for motor assembly. For lighter and more compact applications, SX slides are available. These are made of galvanized sheet and do not require any additional processing (drillings) in order to be mounted on the machine. Moreover, by selecting the SX series, a wide range of motors in compliance with UNELMEC standards is available, maintaining a large number of setting strokes.

Es ist bekannt, dass bei der Anwendung von Scheiben mit doppelter Spreizung eine Geschwindigkeitsveränderung auf der Ausgangswelle zustande kommt, welche dann auf den Achsenabstand der beiden Wellen (Motor-Antrieb) einwirkt. Lösung zu diesem Problem: die Schlitten SL und SMP...NS mit Gusseisenkörper sind praktisch bereit zum Aufbau des Motors. Für leichtere und kompaktere Anwendungen steht die Serie SX zur Verfügung: hergestellt aus verzinktem Blech erfordert sie zur Montage auf die Maschine keine zusätzlichen Bearbeitungen (Bohrungen). Zudem erlaubt die Ausführung der Schlitten der Serie SX eine grosse Auswahl an Motoren laut UNELMEC Richtlinien, unter Beibehaltung von sehr breiten Hubeinstellungen.

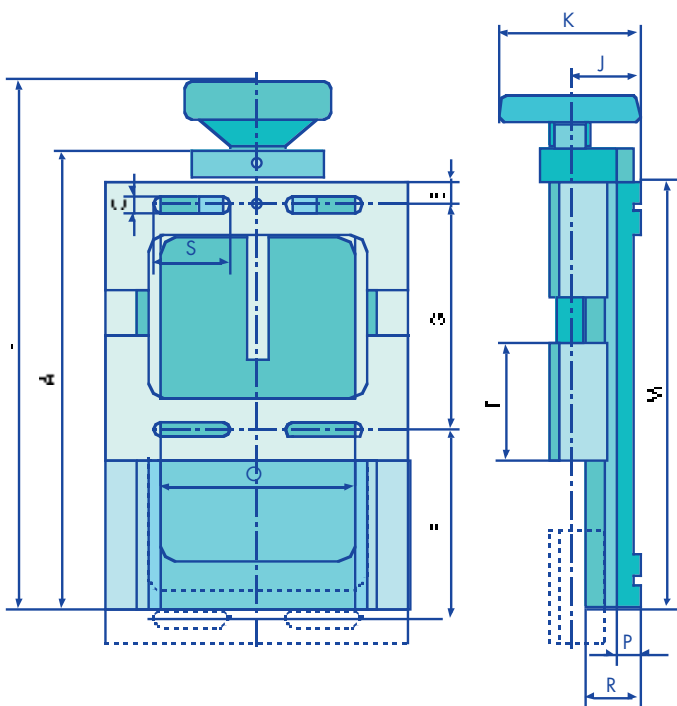
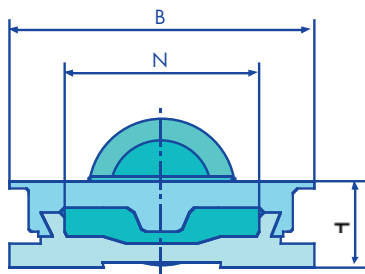

SERIE SL con corpo in ghisa,
pronte per il montaggio del motore.

SL SERIES with cast-iron body,
ready for motor assembly.

SERIE SL mit Gusseisen-Körper,
bereit zum Aufbau des Motors.

SERIE SL



TABELLA DIMENSIONALE (mm) - DIMENSIONS TABLE - GRÖSSENTABELLE

SLITTA SLIDE SCHLITTEN	MOTORI MOTORS MOTOREN	A	B	C	E	H	J	K	L	M	N	O	P	R	S	T	PESO (Kg) WEIGHT GEWICHT
SL.1	71÷90S	255	170	10	17	50	39	80	290	230	112	104	15	28	43	67	5
SL.2	90S÷100L	325	215	12	22	60	48	100	360	305	142	143	15	30	60	85	9
SL.3	112M÷132M	485	275	13	25	80	65	125	530	455	190	170	23	48	62	120	19

TABELLA REGOLAZIONI - ADJUSTMENTS TABLE - REGULUNGENTABELLE

SLITTA SLIDE SCHLITTEN	REGOLAZIONI ADJUSTMENTS REGELUNGEN	56A	63M	71M	80M	90S	90L	100L	112M	132S	132M	160M	160L	180M	180L
SL.1	G			112	125	140									
	F			100	87	72									
SL.2	G					140	140	160							
	F					120	120	100							
SL.3	G								190	216	216				
	F								220	194	194				

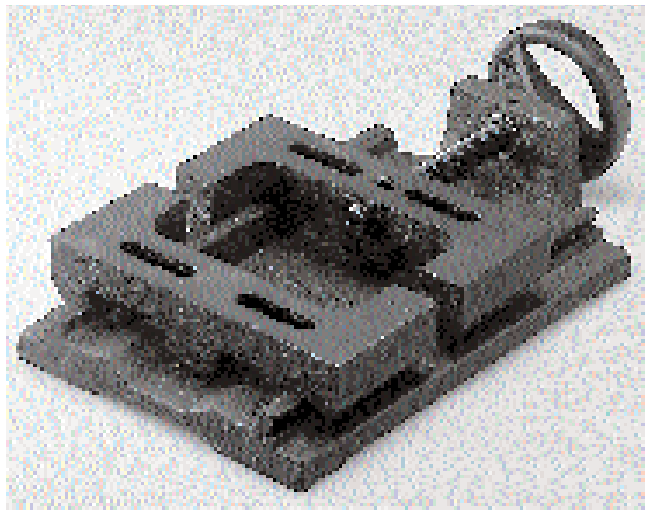
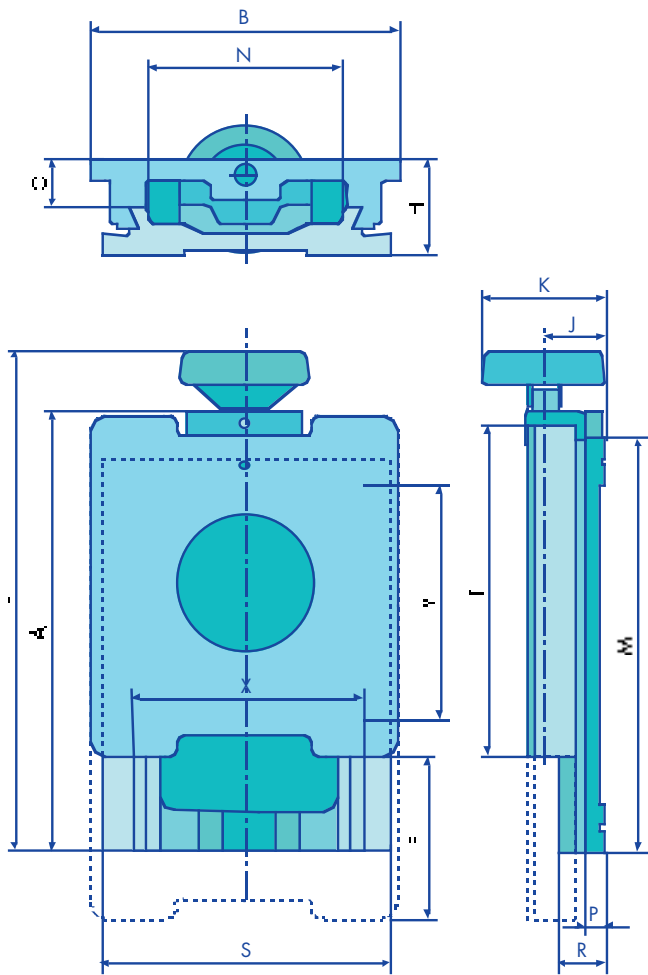

SERIE SMP

SERIE SMP con corpo in ghisa, piastra intera.

SMP SERIES with cast-iron body, full plate.

SERIE SMP mit Gusseisen-Körper, ganze platte.



TABELLA DIMENSIONALE (mm) - DIMENSIONS TABLE - GRÖSSENTABELLE

SLITTA SLIDE SCHLITTEN	MOTORI MOTORS MOTOREN	A	B	C	F	H	J	K	L	M	N	P	R	S	T	PESO (Kg) WEIGHT GEWICHT
SMP.1NS	56÷80	210	145	8	85	50	35	80	245	185	105	14	40	135	155	3,5
SMP.2NS	80÷90L	255	175	24	105	50	39	80	290	230	112	15	28	165	200	7,5
SMP.3NS	100L÷132S	325	210	29	130	60	48	100	360	305	142	15	30	210	257	10,5
SMP.4NS	160M÷180M	460	355	16	150	88	65	125	505	400	245	20	72	305	387	28,5

TABELLA MOTORI - MOTORS TABLE - MOTORTABELLE

SLITTA SLIDE SCHLITTEN	CENTRO CENTER MITTELPUNKT	GRANDEZZE MOTORI - MOTOR SIZES - MOTORGRÖSSEN													
		56A	63M	71M	80M	90S	90L	100L	112M	132S	132M	160M	160L	180M	180L
SMP.1NS	X	90	100	112	125										
	Y	71	80	90	100										
SMP.2NS	X				125	140	140								
	Y				100	100	125								
SMP.3NS	X							160	190	216					
	Y							140	140	140					
SMP.4NS	X										216	254	254	279	279
	Y										178	210	254	241	279

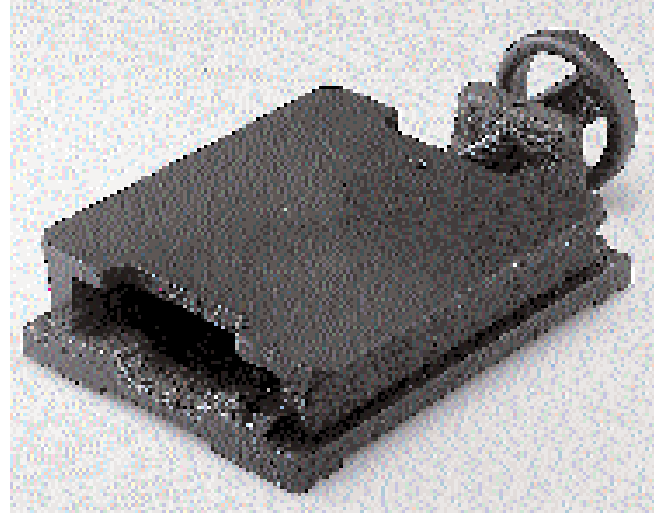
SERIE SX

SERIE SX in lamiera zincata,
pronte per il montaggio del motore.

SX SERIES made of galvanized sheet,
ready for motor assembly.

SERIE SX aus verzinktem Blech,
bereit zum Aufbau des Motors.

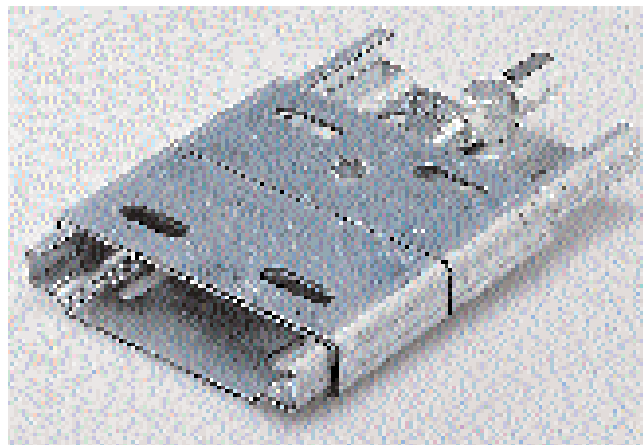
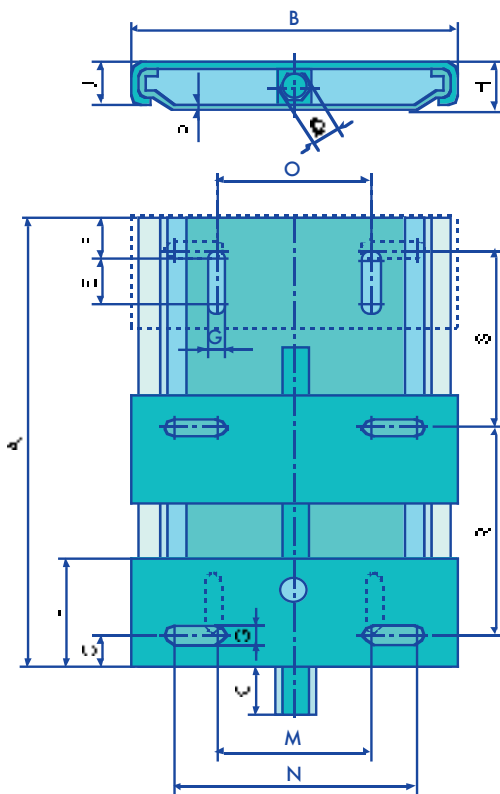

TABELLA DIMENSIONALE (mm) - DIMENSIONS TABLE - GRÖSSENTABELLE

SLITTA SLIDE SCHLITTEN	MOTORI MOTORS MOTOREN	A	B	C	D	E	F	G	H	J	K	L	M	N	O	P	PESO (Kg) WEIGHT GEWICHT
SX.1	56÷80	210	150	20	19	24,5	25	10	27	24	30	65	51	100	80	3	1,7
SX.2	63÷100L	270	195	20	19	40	25	10	27	24	30	65	64	144	115	3	2,5
SX.3	90S÷132M	380	240	27	24	43	30	12	32	29	30	95	96	182	160	3	4,5
SX.4	132M÷180L	450	350	40	24	55	30	15	40	36	30	125	174	284	225	4	9,7

TABELLA REGOLAZIONI - ADJUSTMENTS TABLE - REGULUNGTABELLE

SLITTA SLIDE SCHLITTEN	REGOLAZIONI ADJUSTMENTS REGELUNGEN	GRANDEZZE MOTORI - MOTOR SIZES - MOTORGRÖSSEN															
		56A	63M	71M	80M	90S	90L	100L	112M	132S	132M	160M	160L	180M	180L		
SX.1	R	90	100	112	125												
	S	80	70	58	45												
SX.2	R	90	100	112	125	140	140	160									
	S	140	130	118	105	90	90	70									
SX.3	R					140	140	160	190	216	216						
	S					226	226	206	176	150	150						
SX.4	R											216	254	254	279	279	
	S											200	162	162	137	137	