



WESTCAR s.r.l.

BRAKES

Code 17491

BD Drum Brakes CD Disc Brakes



APPLICATIONS

- Brake for lifting service
- Brake for translater service
- Safety brake
- Emergency brake

TECHNICAL FEATURES

- Welded steel frame in according to DIN 15435 (drum brakes) zinc coated steel frame (disc brake)
- Epoxy resin painting (2 coatings) with RAL 5010 final color
- Manganese phosphated pins (drum brakes), stainless steel pins (disc brakes)
- Light alloy drums with asbestos free glued braking pads (drum brakes)
- Friction coefficient $\mu=0,42$
- Asbestos free lining pads, glued to easy-to-replace plates (disc brakes).
- Braking torque scale indicator
- Protection grade IP 56

OPERATION

- WC Drum and disc brake are negative
- The braking force is obtained by means of a spring that, through a suitable system of levers, transmits its amplified action to the braking pads.
- An electrohydraulic or pneumatic thruster makes an opposite force to the spring, causing the pads open, therefore the brake to release.
- The braking force of the linings against the drum can be modulated by adjusting the spring.
- Braking torque changes depending on braking force modulation.

THRUSTOR TYPES

- **WC** Electrohydraulic WESTCAR (standard)
- **ET** Electrohydraulic ELTMA
- **ED** Electrohydraulic ELDRO
- Pneumatic

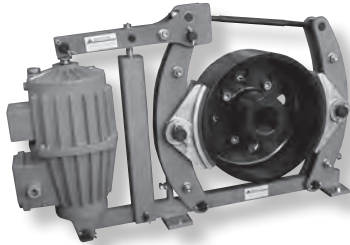

Tab. A

Brake Series BD	THRUSTOR MAXIMUM BRAKE TORQUE Nm						
	WC 22/50	WC 30/50	WC 60/50	WC 75/50	WC 80/60	WC 200/60	WC 300/60
160	120						
200	160	240	-	-	-		
250	210	320	500			-	
315	250	350	700	1.000	1.400		-
400		500	870	1.250	2.100		
500	-		1.100	1.600	2.700	4.400	
630			-	-	3.270	5.400	7.800

ABBREVIATION OF DRUM AND DISC BRAKES

- **RG** Automatic wear compensation device
- **FCU** Maximum wear indicator
- **FCA** Open brake indicator
- **LSM** Manual disengagement lever.
- **SV** Adjustable delay valve
- Protection grade IP 65
- Stainless steel pins instead of phosphated pins (drum brakes)
- Braking drums 50% wider (drum brakes)

BRAKE SELECTION DATA

- Type of application.
- Stop for hour
- Required voltage (standard 230/400V-50Hz)
- Required Optionals
- Drum diameter and width (drum brakes)
- Disc diameter. Standard Disc thickness is 30 mm.
- Air pressure supply (In case of pneumatic actuator)

Drum brakes only

- L special large drums
- INOX stainless steel pins

Disc brakes only

- DX reseccuzione destra
- DS left hand execution

QUICK SELECTION TABLES

- **TAB A** Drum Brake
- **TAB B** Disc Brake



Tab. B

Brake Series CD	Disc Dia. mm	THRUSTOR MAXIMUM BRAKE TORQUE Nm					
		WC 22/50	WC 30/50	WC 60/50	WC 80/60	WC 200/60	WC 300/60
DS 0	250	195	265				
	315	250	340				
	400	330	450				
	450	380	520				
	500	430	530				
DS 1	355	290	435	870			
	400	340	490	980			
	450	390	530	1060			
	500	440	575	1150			
DS 2	450			1350	2700	4500	
	500			1500	3000	5000	
	560			1700	3400	5700	
	630			1850	3700	6200	
	710			2100	4200	7000	
DS 3	630	-	-		3900	6500	9750
	710				4410	7350	11000
	800				5050	8500	12750
	1000				6300	10500	15750
	1250				7700	12800	19000

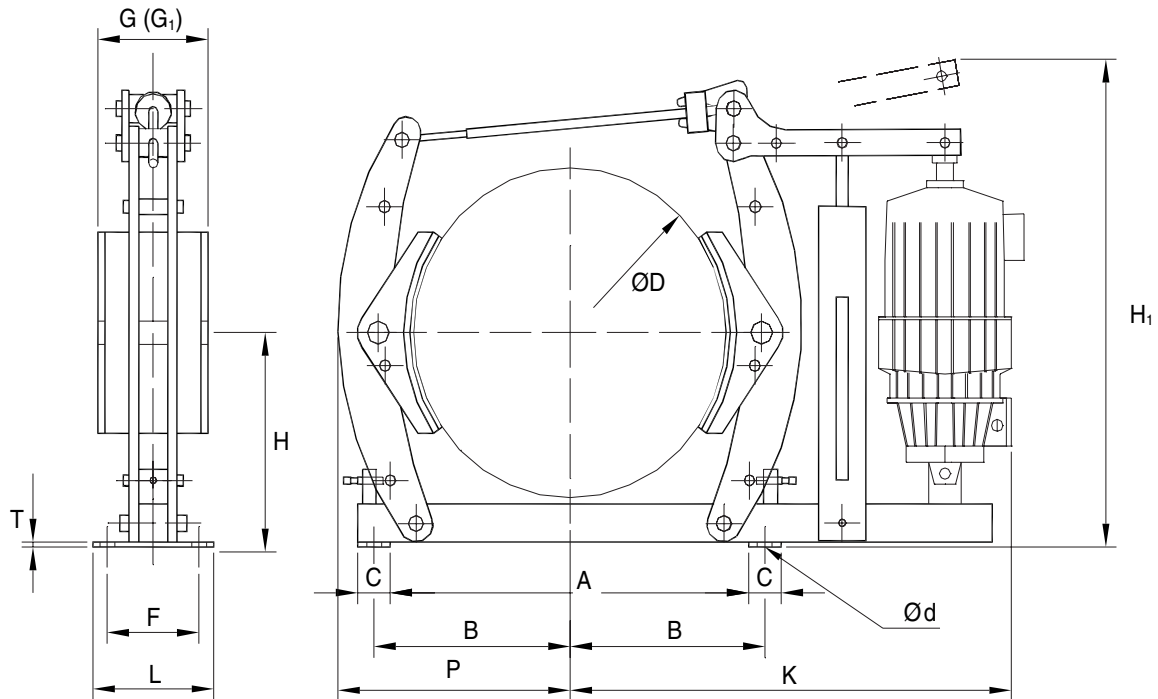

AUTOMATIC WEAR
COMPENSATION DEVICE

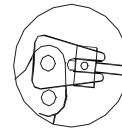

Series BD	Thruster WC	Dimensions mm														Brake Weight Kg	Total Weight Kg		
		D	A	B	C	Nr	d		G	G ₁	H	H ₁ max	K	L	P			T	
							Ø	F											
160	22/50	160	200	120	40	4	12	50	55	-	130	376	362	80	140	10	9	16	
200		200	250	145			14	55	70	105	160		471	386	92		165	11	18
200	30/50	250	310	180	50	4	18	65	90	135	190	517	443	110	207	12	26	25	
250	22/50												453				32	36	
	315	30/50	315	380	220	60	4	18	80	110	165	230	523	478	120	255	15	30	41
60/50		516												32				36	
75/50		566												36				43	
80/60.2		595												36				50	
400	30/50	400	480	270	60	4	22	100	140	210	280	600	669	150	312	15	60	62	
	60/50												688				69	69	
	75/50												693				93	96	
	80/60.2												712				96	100	
500	60/50	500	586	325	60	4	22	130	180	270	340	800	723	180	400	15	100	122	
	75/50												712				100	122	
	200/60												723				122	122	
630	80/60.2	630	700	400	100	4	27	170	225	335	420	888	903	250	475	20	143	165	
	200/60																122	165	167
	300/60																122	167	167

G₁ Increased with brake drum

Dimensions are subject alteration without notice

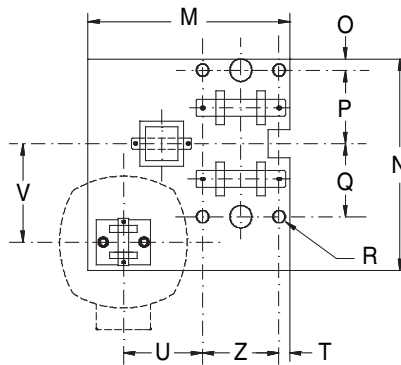
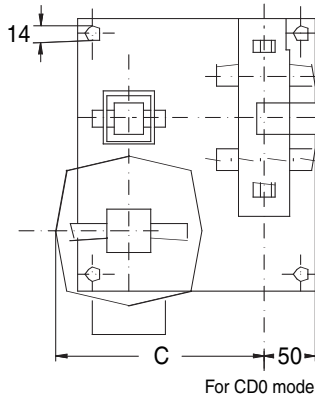
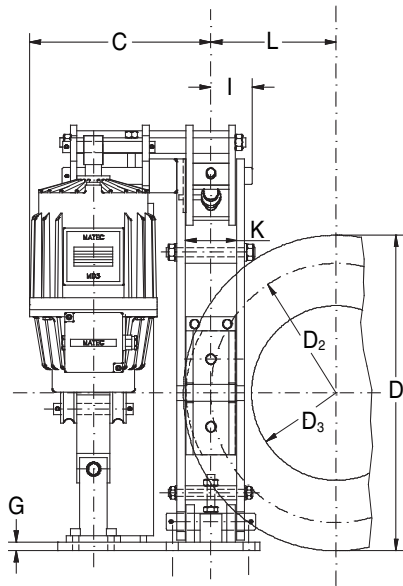
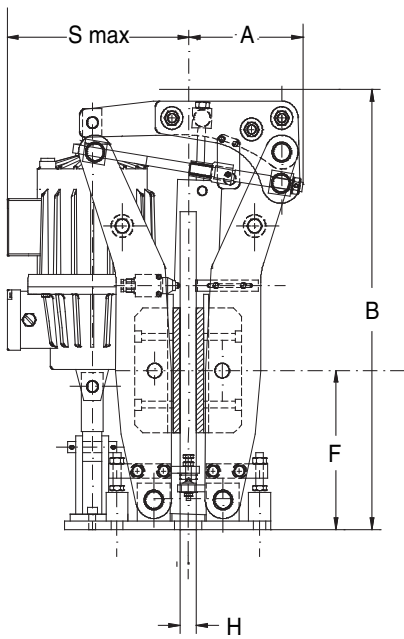

Series CD	DISC			
	D ₁	D ₂	D ₃	L
0	250	200	110	98
	315	260	170	130
	400	345	255	173
	450	395	305	197
	500	445	355	222
1	355	275	160	138
	400	320	205	160
	450	370	255	185
2	500	420	305	210
	450	350	200	175
	500	400	250	200
	560	460	310	230
	630	530	380	265
3	710	610	460	305
	630	500	310	250
	710	580	390	290
	800	670	480	335
	1000	870	680	435
	1250	1120	930	560

Right-hand brake with option RG-FCU-LSM as drawn.
Left handling on request.
All data subject to change without notice.

Series CD	Thrustor WC series	Dimensions mm																			
		A	B max	C	F	G	H	I	K	M	N	O	P	Q	R		S max	T	U	V	Z
															Nr	Ø					
0	22/50	123	487	201	160	15	30	50	-	230	260	15	-	-	4	14	216	-	-	-	-
	214			241																	
1	22/50	190	650	221	230	15	30	62	70	300	300	20	80	180	4	18	246	20	90	140	120
	30/50			234													268				
	60/50			246													276				
2	60/50	210	800	316	280	15	30	75	90	370	375	20	130	130	4	22	311	20	145	175	140
	80/60			332													330				
	200/60			352													341				
3	80/60	235	1050	352	370	20	30	95	120	410	460	20	180	180	4	27	350	30	155	187	160
	200/60			372													361				
	300/60																				

Dimensions are subject to alteration without notice